

Connecting
people with
Intelligent
building solutions

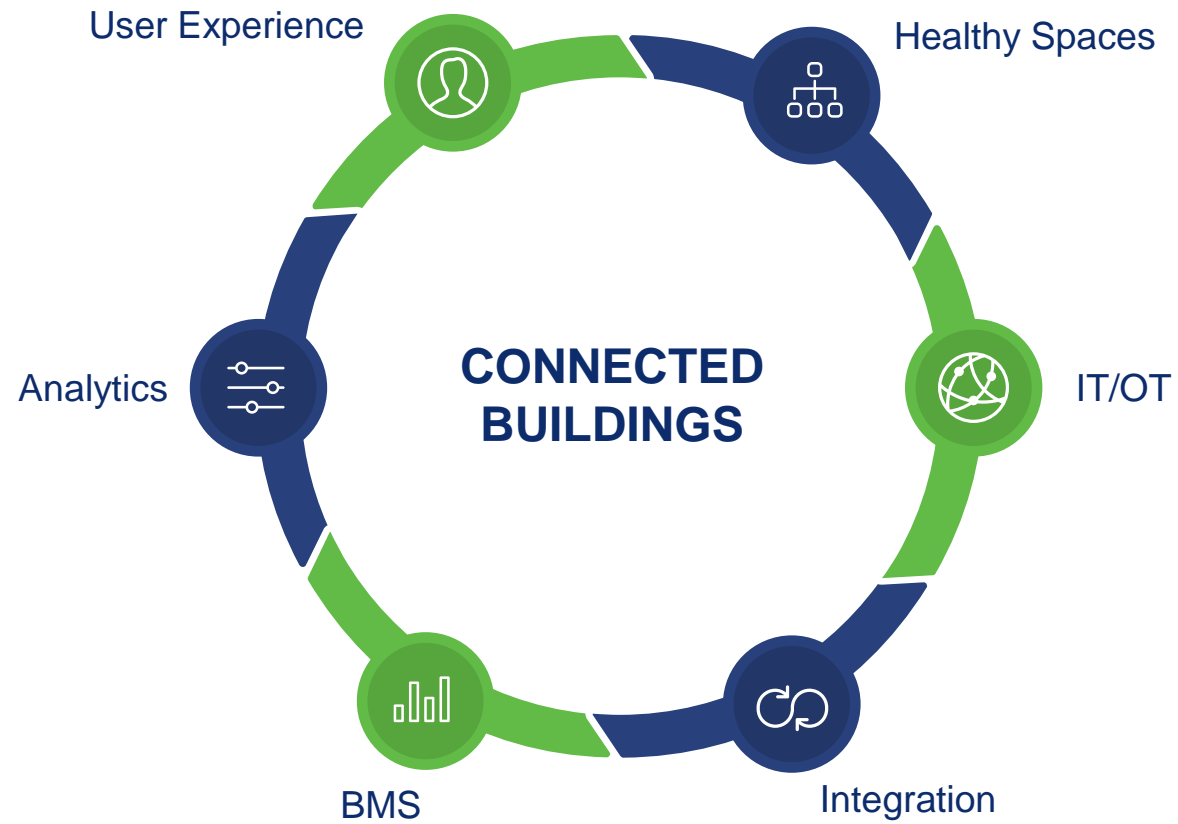

Creating Smart Buildings



Creating a Future Ready Building

Open

- Open products
- Open market strategy
- Free programs & apps

Flexible

- Flexible architecture
- Clients have options and control

Innovative

- Future ready infrastructure

Advanced Services are Needed to Support New Requirements

Energy Efficiency -\$3

Energy Positive Building



Space Efficiency - \$30

Space Management



Occupants' Expectations -\$300

Multi-Services App for Occupants



Technology is Driving Expectations

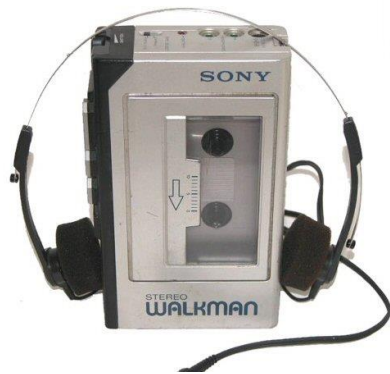

Technology is Driving Expectations



Technology is Driving Expectations



From Connected Devices to Enchanted Objects

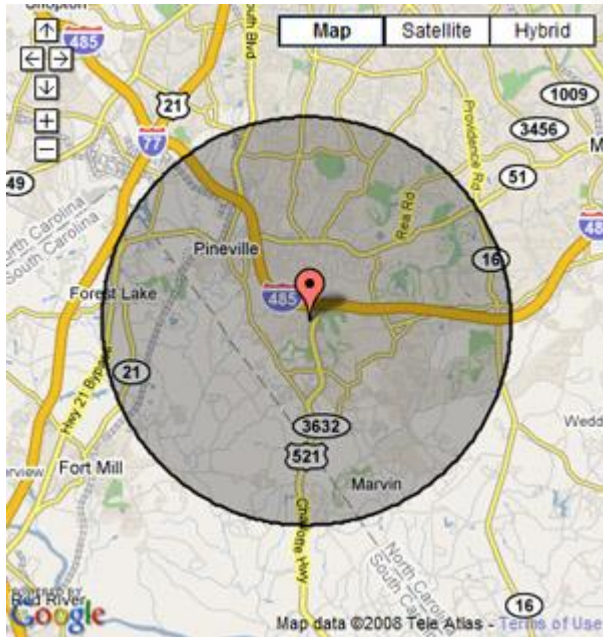

Smart/Enchanted for Who?



Facility Manager



Building Owner



Occupants



What's a Typical Office Worker's Day Like?

Check the activities of the company daycare

Find a parking space

Book a meeting room

Search for a free desk

Consult the public transport schedule

Choose the best way to get to work

Report a coffee machine failure

Book a table at the restaurant for a business lunch

Avoid waiting in the cafeteria

Find an employee's office

Subscribe to the next available electric vehicle charging station

Worried about COVID

Typical challenges faced by Owners / Facility Managers

“Unable to identify our operating costs, where to reduce them?”

“Flexible offices, capable of adapting the layout to the evolution of the project teams.”

“Not enough meeting rooms, many zombie meetings.”

“Reduce office rental costs, promote teleworking and set up hot-desking.”

“Location easily accessible by public transit, in a pleasant area to attract the best talent.”

“Manage car chargers to prevent employees from leaving their uncharged cars at the office and putting UBER costs to return home on their expense account.”

“Occupant’s dissatisfaction rate rises with the investment to decrease the dissatisfaction rate !”



The Spine (OT Network)

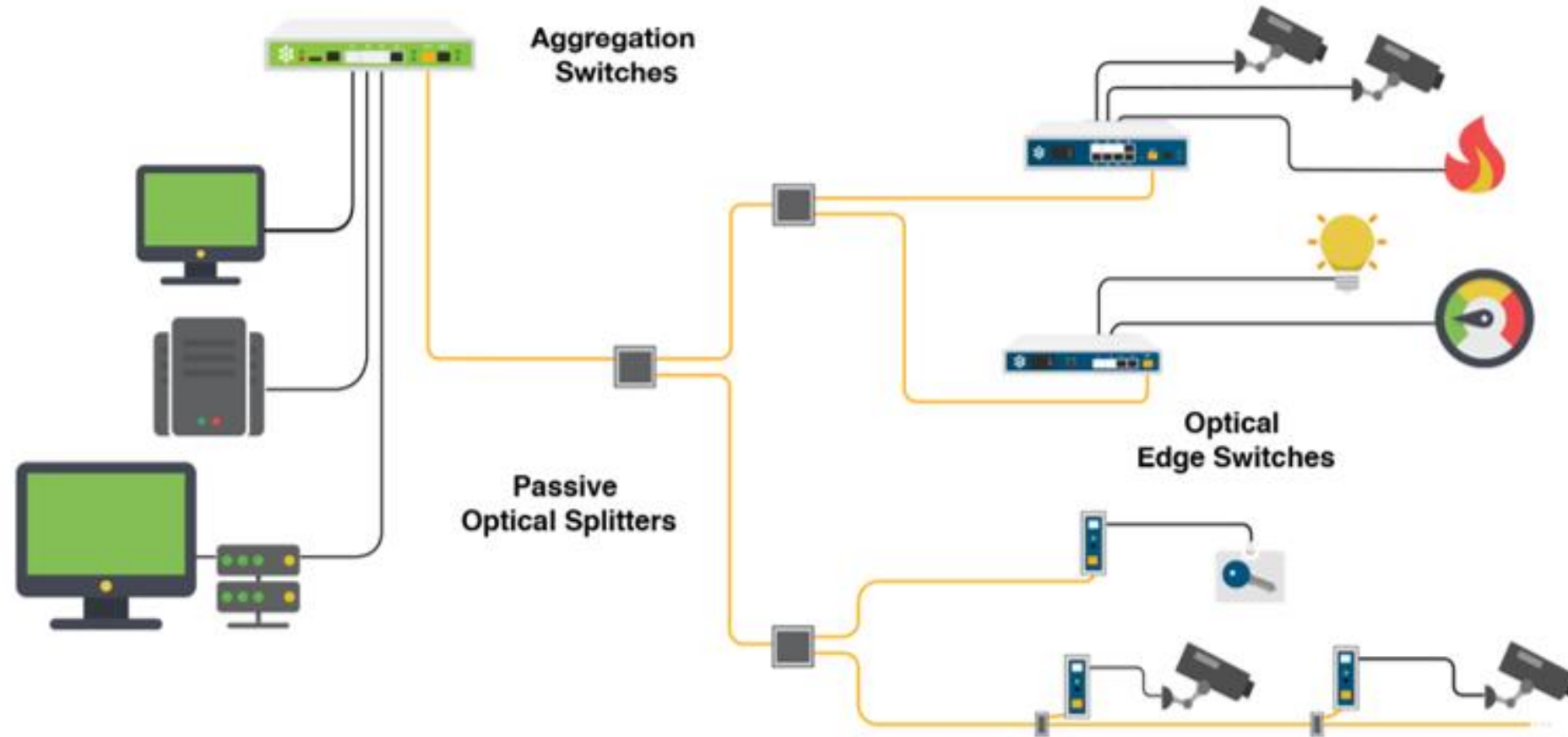

FLAT IP ARCHITECTURE

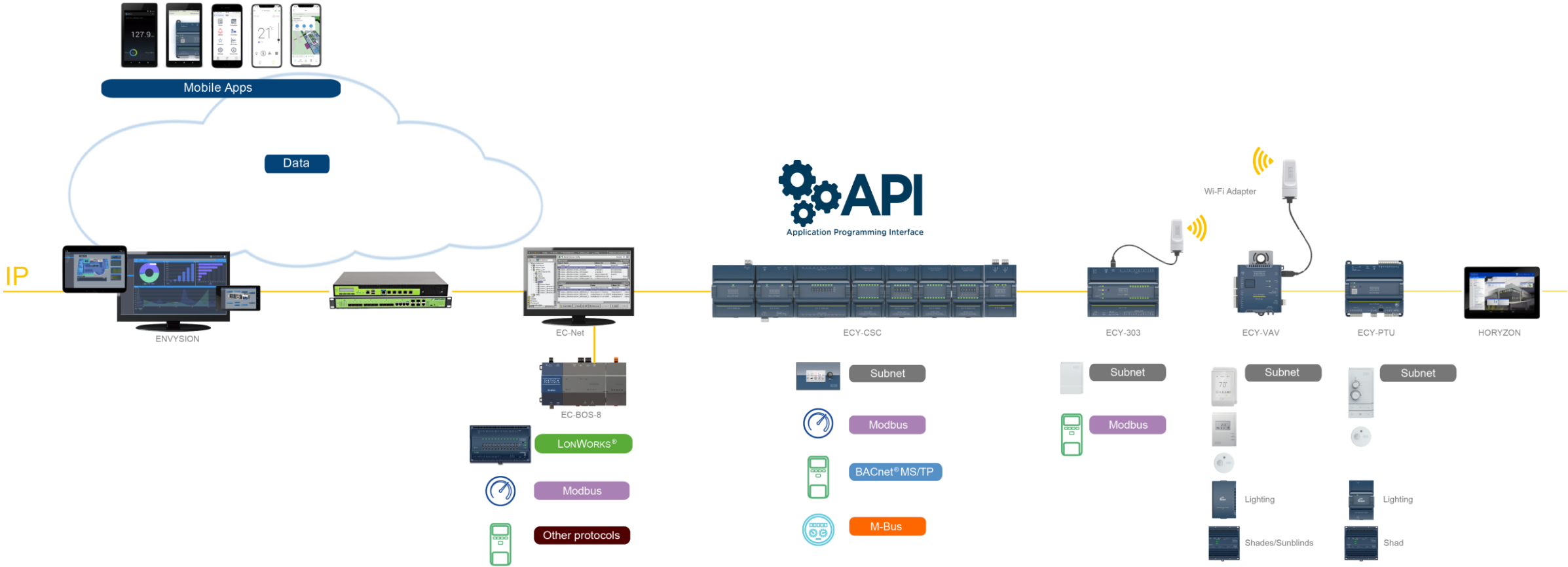

Real Time Reliable Information



Growing Number of “Connected Devices”



3rd Party Connected Devices

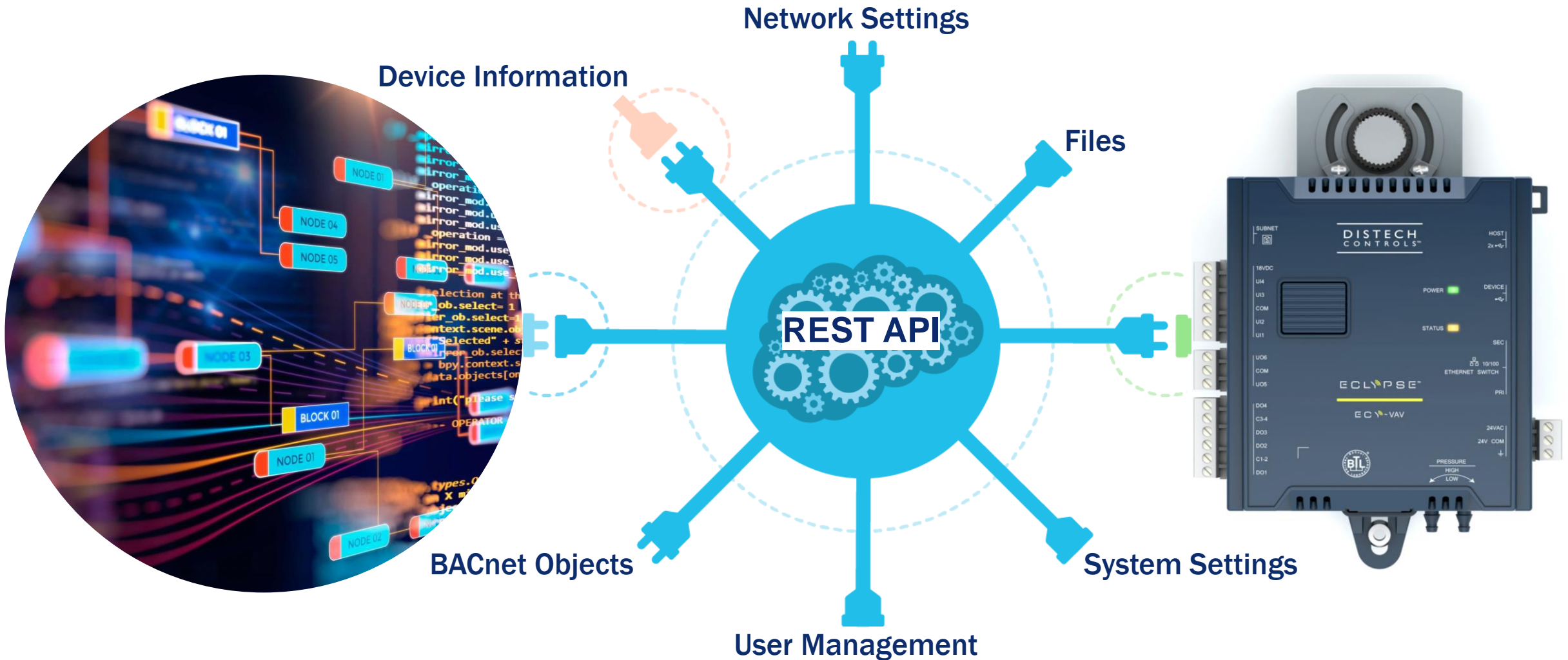

Growing Number of “Connected Devices”

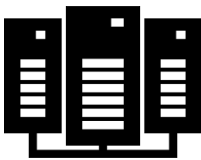

Room devices



Space Management



Transportation



Access Control



IPS



Mobile App



Connectors



Single UX for all Connected Devices



**HVAC
Control**



**Lighting
Control**

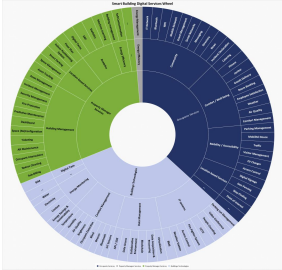

**3rd Party
Integration**

REST API

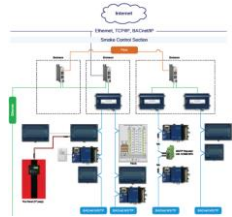

**Fire &
Smoke
Control**



**Physical
Access
Control**



**Video
Monitoring**



Utilization Meeting Rooms or Common Spaces



EXIT

Dish Return

CHONG KING
CHINESE MEAT
[Image of two people]

Christopher St
Sheridan Sq

THE EARTH IS WHAT
ALL HAVE
COMMON



9
DOOR



← Restrooms

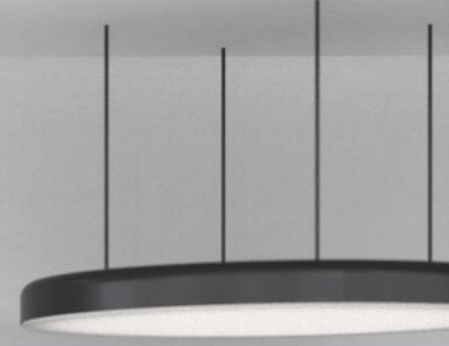

Available Spaces: 17 (current)
Occupied Spaces: 0 (current)



Advanced Reporting

Accelerate investigations, rapidly identify license plates present near crime scenes and receive patrol route efficiency with AutoMatic's ALPR reports.

Vehicle Behavior Analysis

Automatically detect suspicious vehicle behavior, such as speeding or traveling in the wrong direction, and speed up security responses to potential threats with AutoMatic's advanced vehicle analytics.

Augmented Video Surveillance Cameras

Transform standard video surveillance cameras into ALPR units and read the license plates of vehicles moving at speed up to 75 MPH with AutoMatic's Power Reader Cloud.



Unified Interface

Increase your security team's situational awareness by automatically displaying live and recorded footage from video surveillance cameras located around your ALPR units when a vehicle of interest is detected.

Single UX for all Connected Devices

AcuityBrands Lenox Square Atlanta, GA - USA Hi, [Facility User]

WELCOME TO YOUR TRAFFIC OVERVIEW DASHBOARD

ALL TRAFFIC ZONE NOTIFICATIONS

- ROUNDABOUT** (3 notifications) Vehicles are proceeding **two minutes slower** than usual for over five minutes. **Take action to resolve.**
- INNER CIRCLE RIGHT** (2 notifications) Vehicles are now proceeding within acceptable time frame for over five minutes.

Map showing traffic zones: PEACHTREE ZONE, ROUNDABOUT ZONE, LENOX & KINGSBORO ZONE, LENOX & WRIGHT ZONE, EAST PACES ZONE.

ZONE LENOX & KINGSBORO

- 123 VEHICLES ENTERED & EXITED DURING PAST 5 MINUTES
- 15MPH AVERAGE VEHICLE SPEED
- 4/4 VIDEO NODES MONITORING TRAFFIC
- 4/4 LANES OF TRAFFIC BEING CAPTURED

TRAFFIC ZONE STATUS LEVEL

CONGESTED	NORMAL
ROUNDABOUT	LENOX & KINGSBORO
NORMAL	NORMAL
LENOX & WRIGHT	EAST PACES
NORMAL	HEAVY
PEACHTREE	LENOX & PEACHTREE

TRAFFIC PROGRESS AND OUTLOOK (DAY SPAN)

TRAFFIC PROGRESS AND OUTLOOK (WEEK SPAN)

TODAY'S HIGHLIGHTS

VEHICLES COUNTED THIS HOUR	AVG. SPEED IN ALL ZONES	CONGESTION COUNT THIS HOUR	CURRENT TRAFFIC LEVEL
568	10MPH	1	ABOVE AVG.

+ PIN DATA ITEM

AcuityBrands Lenox Square Atlanta, GA - USA Hi, [Facility User]

WELCOME TO YOUR PARKING OVERVIEW

PARKING ZONE & LOT NOTIFICATIONS

- LENOX PKWY LOT 5** (2 notifications) Vehicle parked in no-parking zone.
- LENOX PKWY LOT 2** (4 notifications) Vehicle towed out of no-parking zone.
- LENOX PKWY DECK 2 LEVEL 3** (2 notifications) Abandoned vehicle towed.

PARKING SPACE NOTIFICATIONS

- TWO HOUR SPACE 1** (2 notifications) Vehicle parked 2.1 HRS. **Take action.**
- TWO HOUR SPACE 7** (4 notifications) Vehicle departed within 2 HR limit.
- RESERVED SPACE 1** (1 notification) Vehicle parked. Recommend Verifi...

Map showing parking lots: L1, L2, L3, L4, L5, D1, D2, D3A, D3B.

LENOX PKWY LOT 5

- 75% CURRENT CAPACITY
- 65% PREDICTED CAPACITY IN 1HR
- 58% YESTERDAY'S CAPACITY THIS HR

83 CURRENTLY PARKED CAR COUNT

2.1 CURRENT AVG. STAY (HRS)

110/110 PARKING SPOT COUNT STATUS

64 YESTERDAY'S CAR COUNT THIS HR

3.1 AVG. STAY YESTERDAY (HRS)

10/10 VIDEO NODES SENDING DATA

PARKING LOT OVERVIEW

- LENOX PKWY LOT 1: 32%
- LENOX PKWY LOT 2: 52%
- LENOX PKWY LOT 3: 73%

PARKING DECK OVERVIEW

- LENOX PKWY DECK 1: 65%
- LENOX PKWY DECK 2: 12%, 48%, 82%, 77%, 91%

HANDICAP SPACES BEING WATCHED

RESERVED SPACES BEING WATCHED

TWO HOUR PARKING SPACES

LOT 3: 2.13 HRS LOCATION STAY DURATION

Your Digital Assistant can manage more than just comfort



**Ready-to-Use
Solutions for
Office**

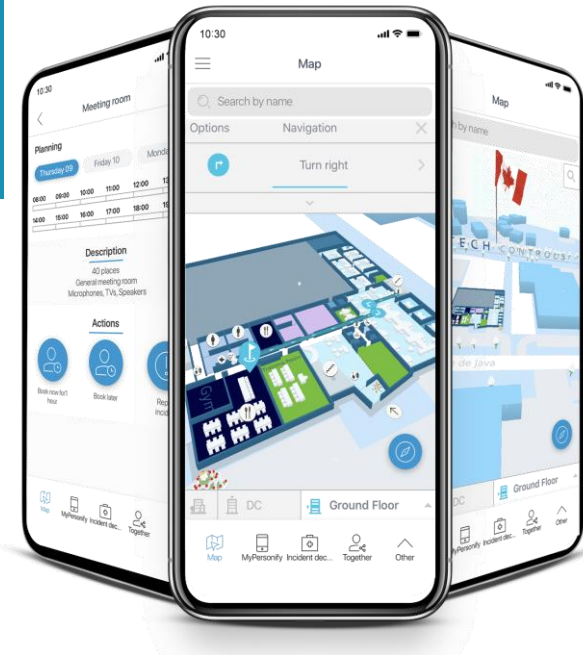

Custom Mobile Apps for all things Building



Unlimited Possibilities with Customized Apps

Room Control Solution

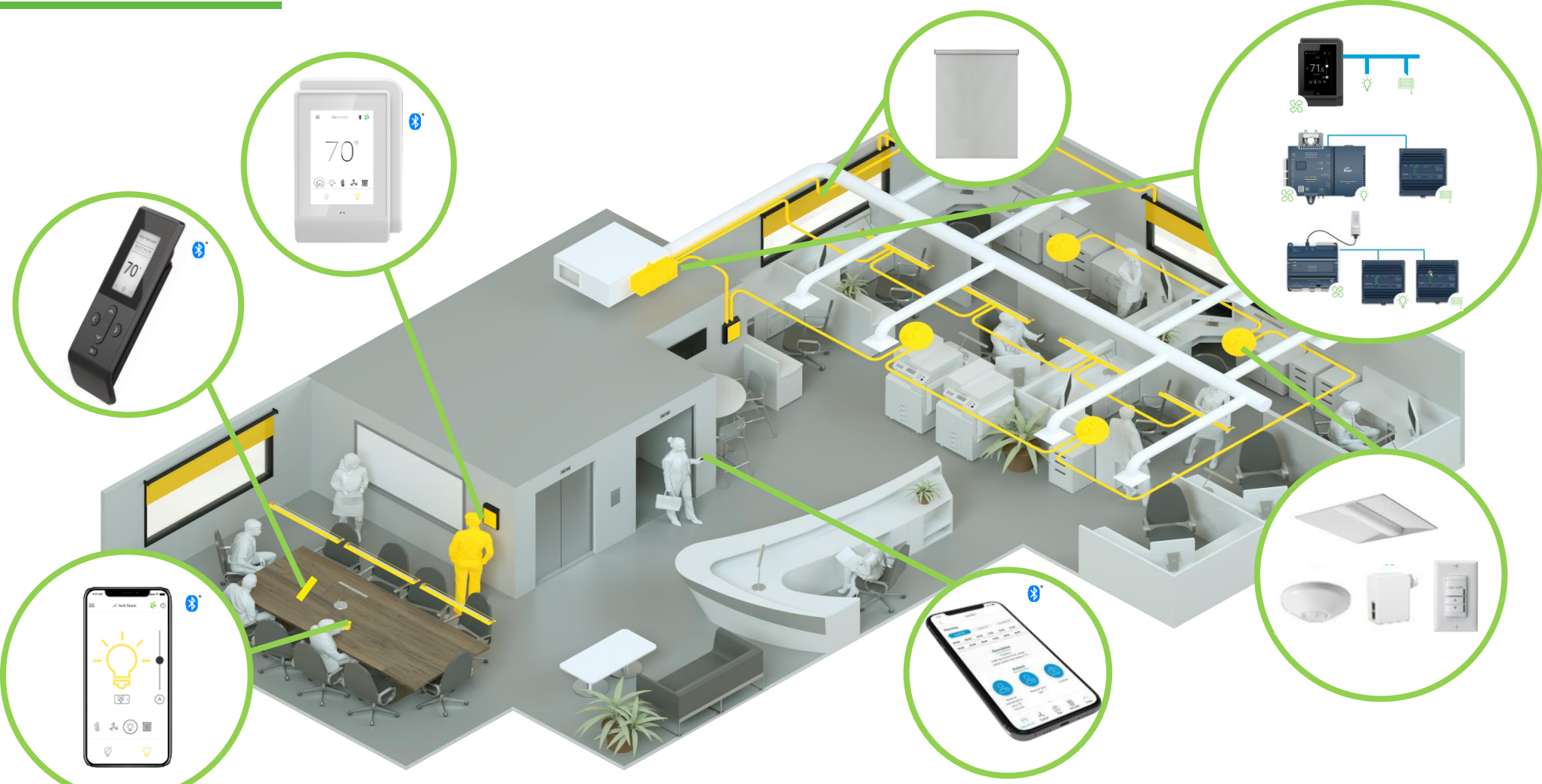

Indoor Positioning System



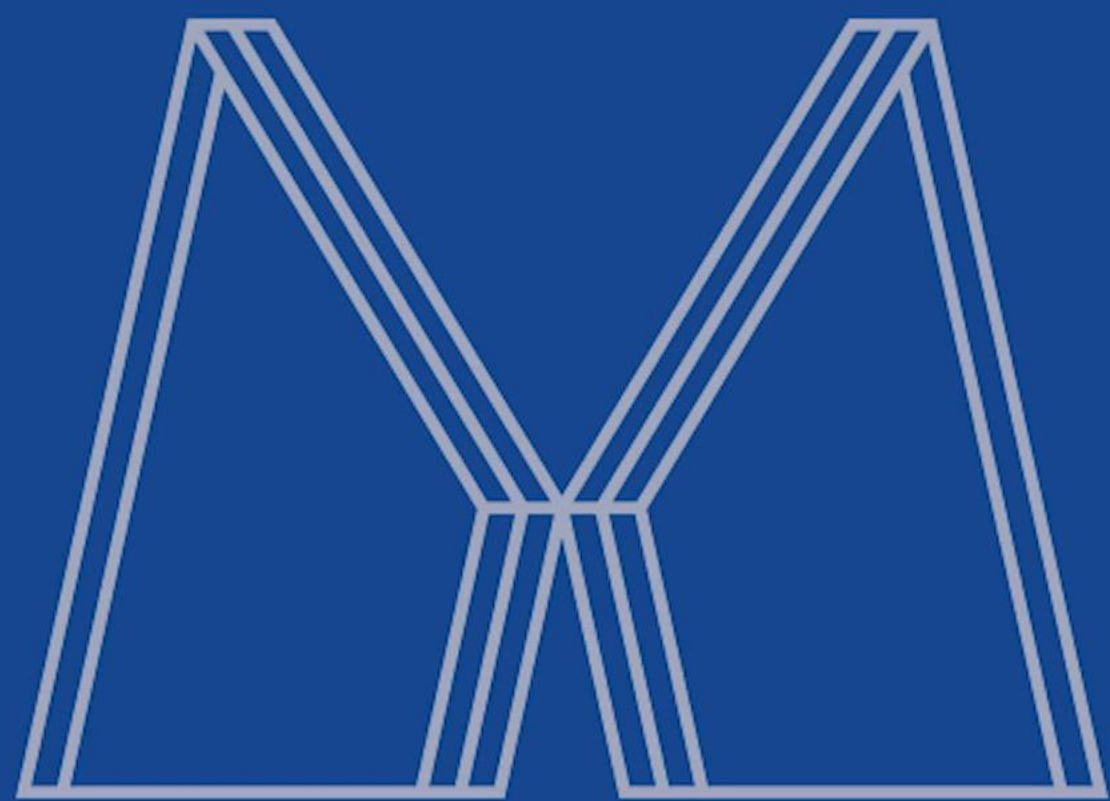

MEMORIAL CITY

Proactive Measures

- Enhanced Indoor Air Quality
- Detecting Occupied Spaces
- Infection Control
- Contactless Comfort Management
- Make Sure Social Distancing can be Respected
- Provide Access to Healthy Occupants Only





Enhanced Indoor Air Quality

- Increase the ventilation rate
- Increase the rate of air renewal
- HEPA Filter
- Kill bacteria and inactivate viruses in HVAC systems

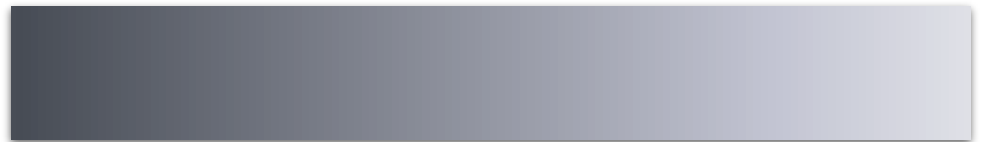

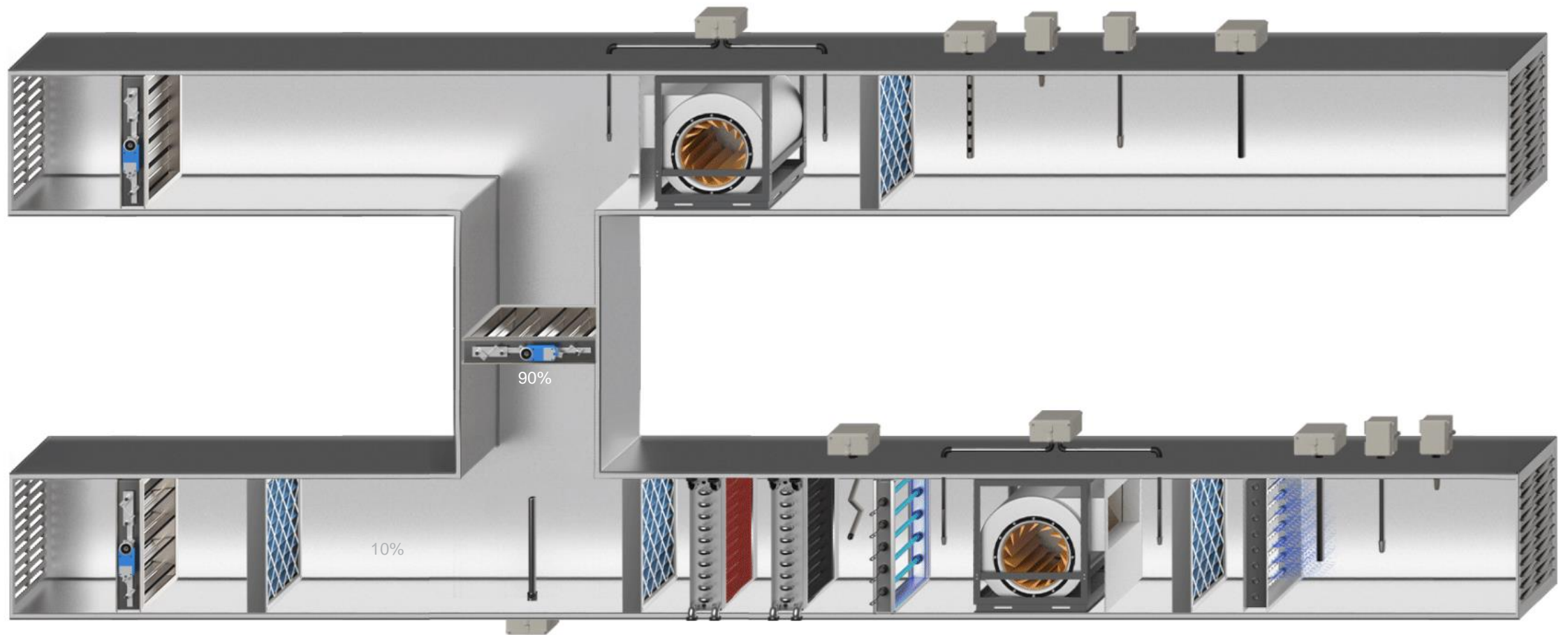

Detecting Occupied Spaces



Optimize the use of your spaces by considering new trends in work organization

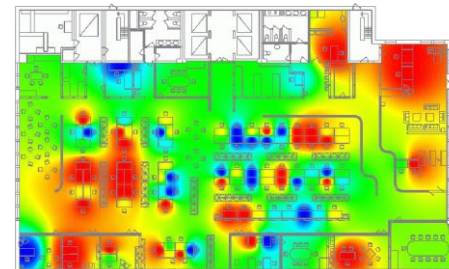

Provide Access to Healthy Occupants Only



Preventing sick people from entering your facility.

Healthy and Trustworthy Buildings

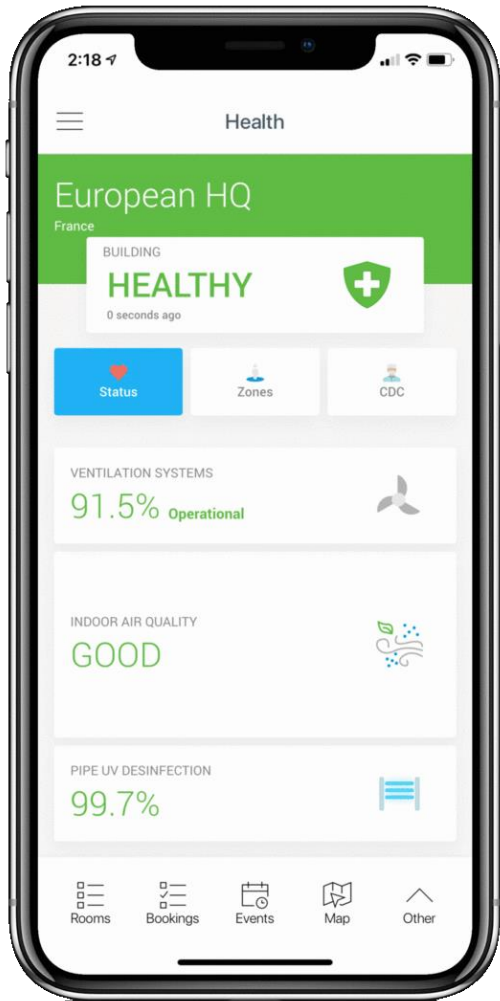

The desktop browser view shows the "Return to Work Dashboard" for "North American HQ" in "QC, Canada". The main status is "BUILDING HEALTHY" with a green cross icon and "1 min ago". There are four sections: "VENTILATION SYSTEMS" at 91.1% Operational, "INDOOR AIR QUALITY" at GOOD, and "PIPE UV DESINFECTION" at 98.6%. Below these are three columns: "Zone safety status" with a list of zones (Chocolate, 007, The Incredibles, Die Hard, Indiana Jones, Spiderman, Pirates of the Caribbean, #Chef, Star Wars, Lounge, Marvel) and their status; "What we're doing to help keep you safe" with four items: Enhanced Indoor Air Quality, Infection Control, Touchless Interactions, and People Tracking; and "CDC Recommendations" with icons for hand washing, face coverings, and social distancing. At the bottom, there are two tweets from "Distech Controls" (@DistechControls) discussing building technology and occupant wellbeing.



Thank You

 Well-Being

 Space Management

 Energy Efficiency

