



WHEN TRUST MATTERS

Introduction to Cannabis and Energy Efficiency

AEE CT
November 16, 2021

Ryan Pollin
Dan Birleanu

15 November 2021

Agenda

- 1 Introduction
- 2 Grow Cycle
- 3 Energy Consuming Equipment
- 4 Efficiency Opportunities

Not covered today:
Greenhouses
Outdoor cultivation

About the Presenters

Dan Birleanu Principal Consultant

Commercial and Industrial program
implementation
Program development
Building and systems modeling

MA Technical Assistance Modeling
Boulder County Energy Assessments
Efficiency Maine Trust Programs

Ryan Pollin, PE, CEM Senior Engineer

C&I program implementation and evaluation
Cannabis research, implementation, and
evaluation

Com Ed Market Research
CA Title 24 Code Support
Policy and Program Advising

An Industry Emerges From The Shadows

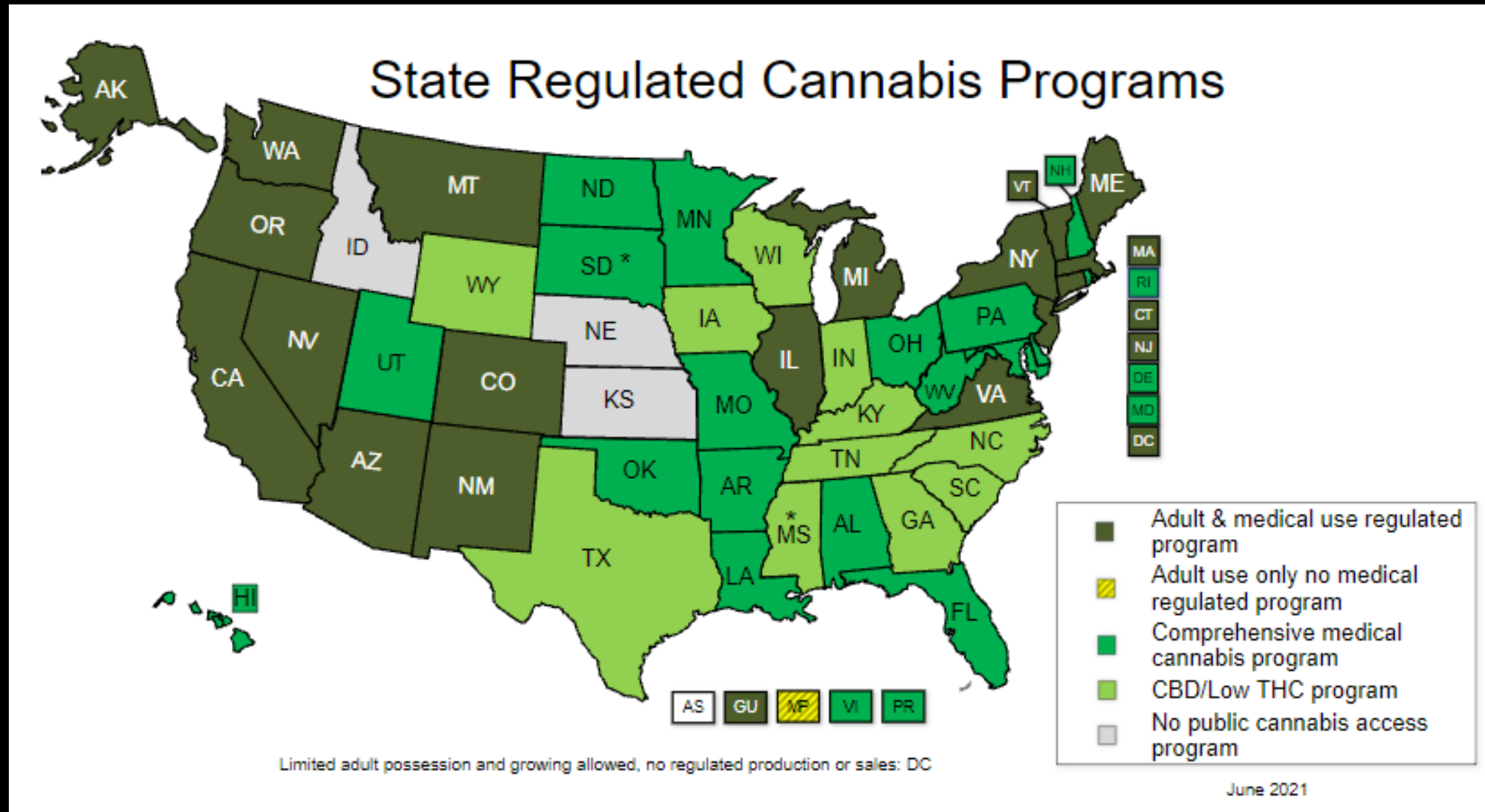



It's a Plant

What drives production?

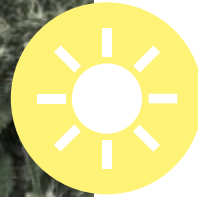

Light



Environmental conditions



Water



Nutrients and CO₂

Grow Cycle

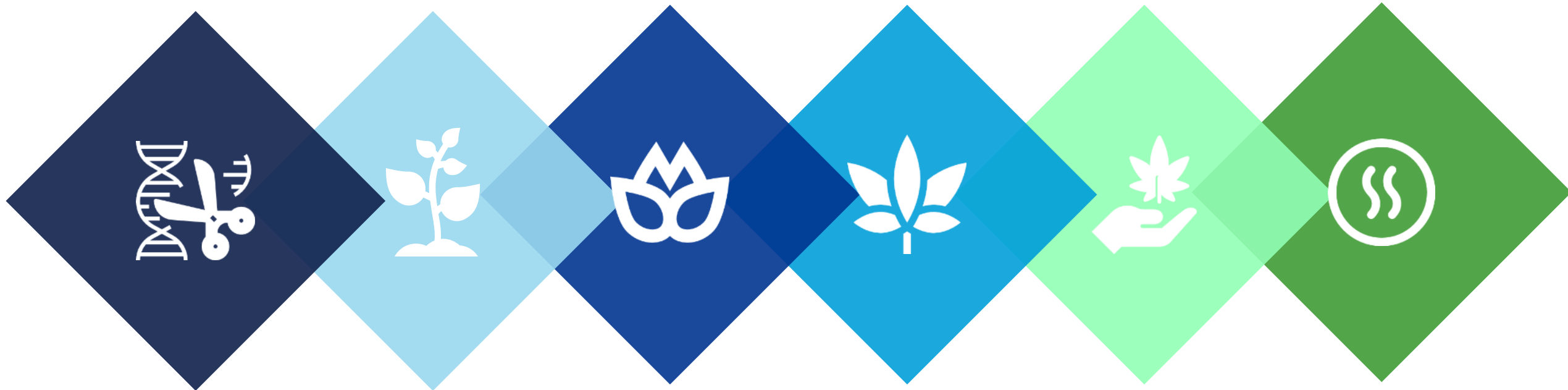

Germination
or Cloning

Seedlings

Vegetative

Flowering

Harvest

Drying,
Curing,
Processing

Germination or Cloning

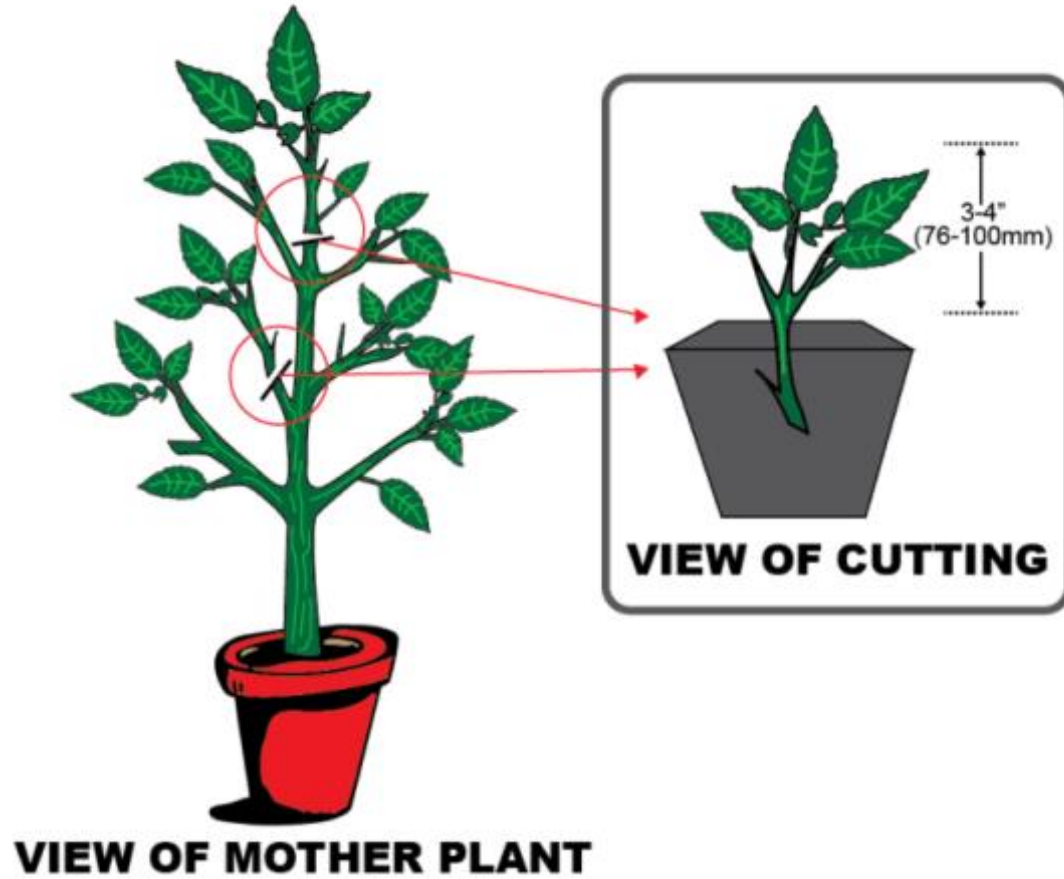

Seedlings



Vertical grows in racks



T5HO fluorescent or LED

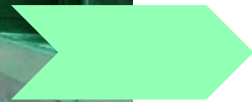

Lighting 18 to 24 hrs./day

Vegetative



Transitioned to full size pots and grow rooms



MH (bluer spectra) or LED

Debate about need for dark period

Advanced cultivation techniques
18 – 24 hour photoperiod

Flowering

➔ 12 hour photoperiod, highest intensity

➔ High-Pressure Sodium or LED



Drying and Curing

GROW CYCLE



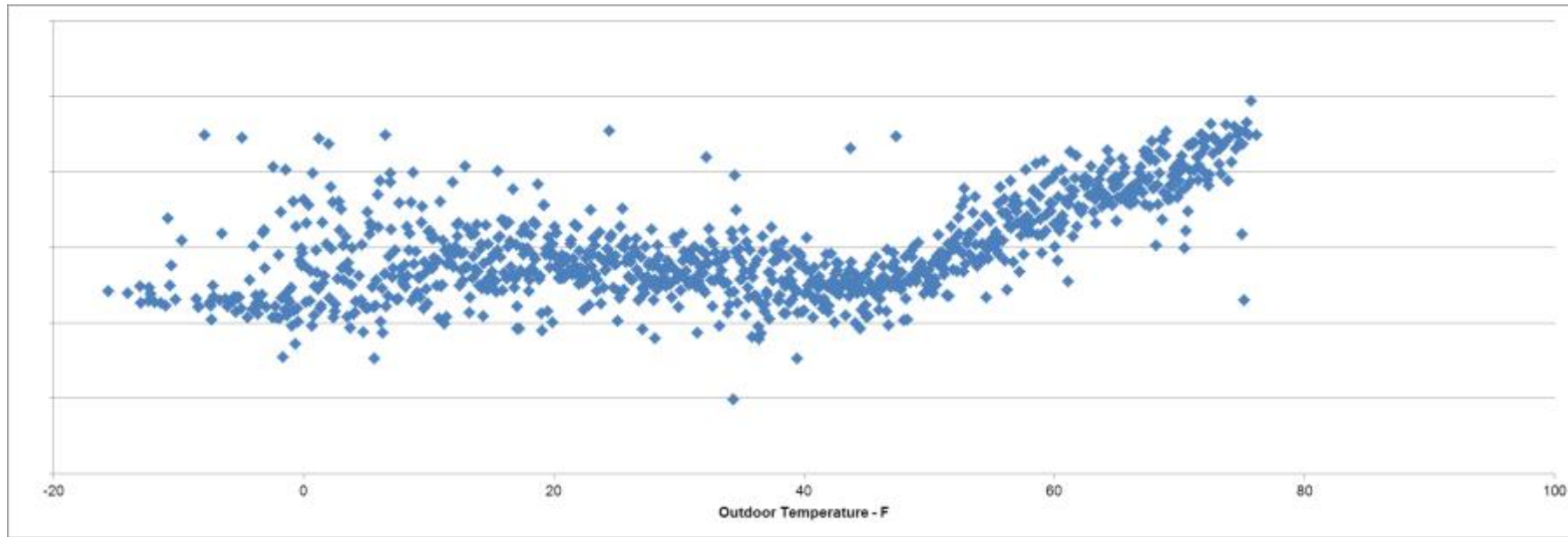

II. Facility Energy Use

- Energy Use
- Energy End Use
- Load Shapes
- Weather Dependence

What does a typical facility include?

Grow Rooms
(by growth phase)

Commercial Kitchens

Retail Space

Support Spaces

Processing
Drying/Curing | Trimming | Extractions

Equipment Loads

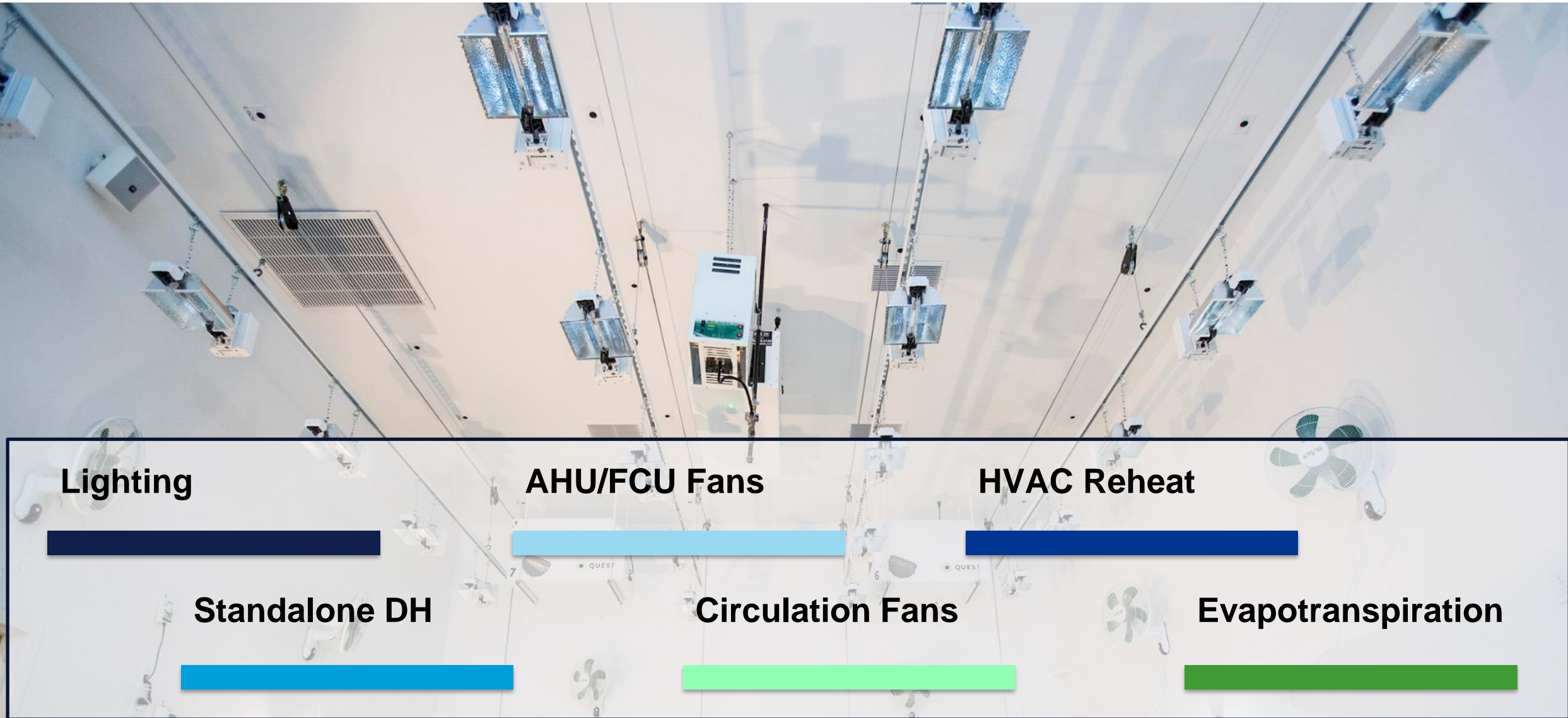

Energy End-Uses

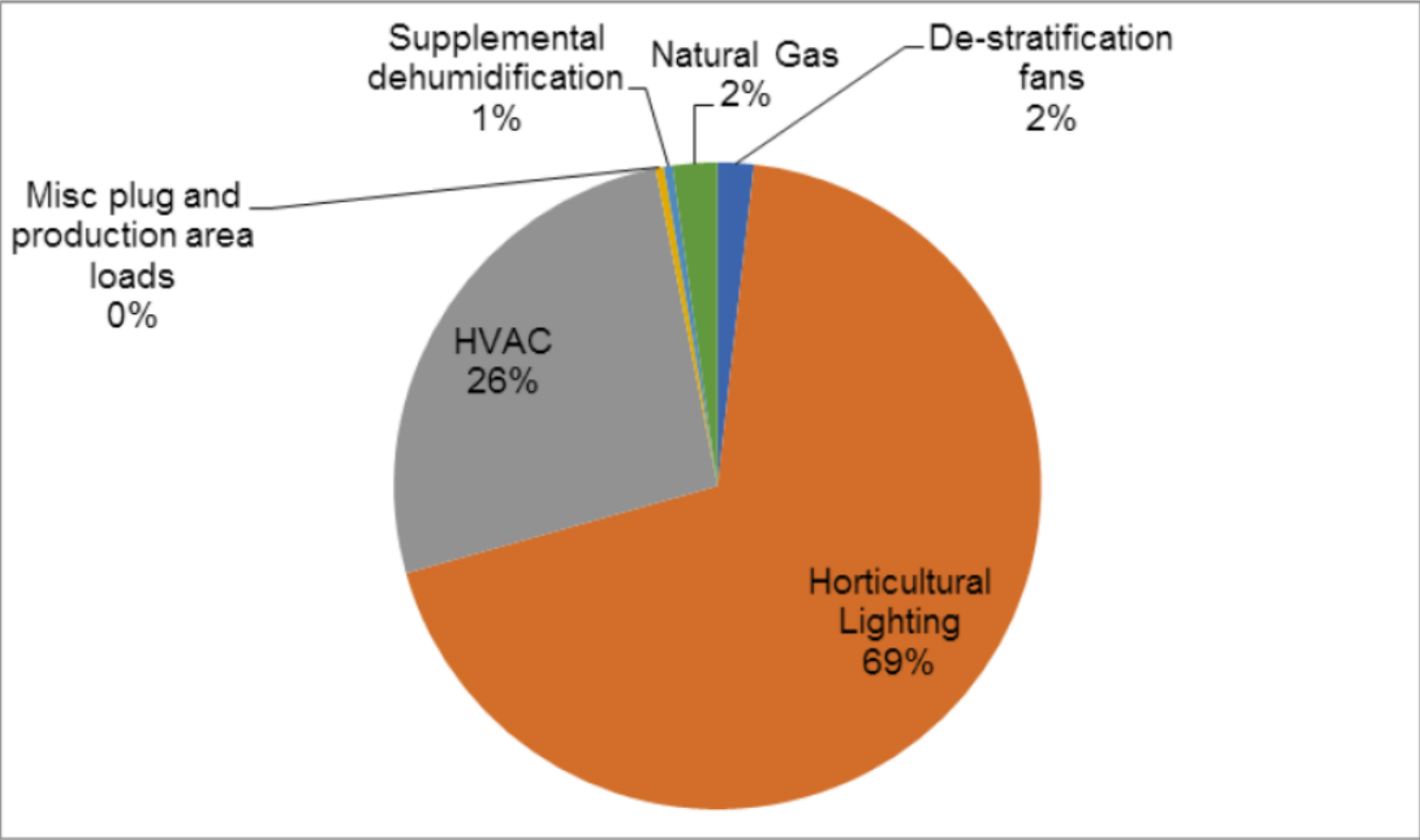

Prior ERS study: <https://www.bouldercounty.org/environment/sustainability/marijuana-offset-fund/>

Operational Profile

How will the facility operate?

- Will they have all rooms fully loaded?
- What is the downtime between harvest?
- Will they stagger the operation of flower rooms?

They should:

- 50% of rooms on/50% of rooms off
- Reduced equipment sizing
- Reduced demand impact

Load shapes

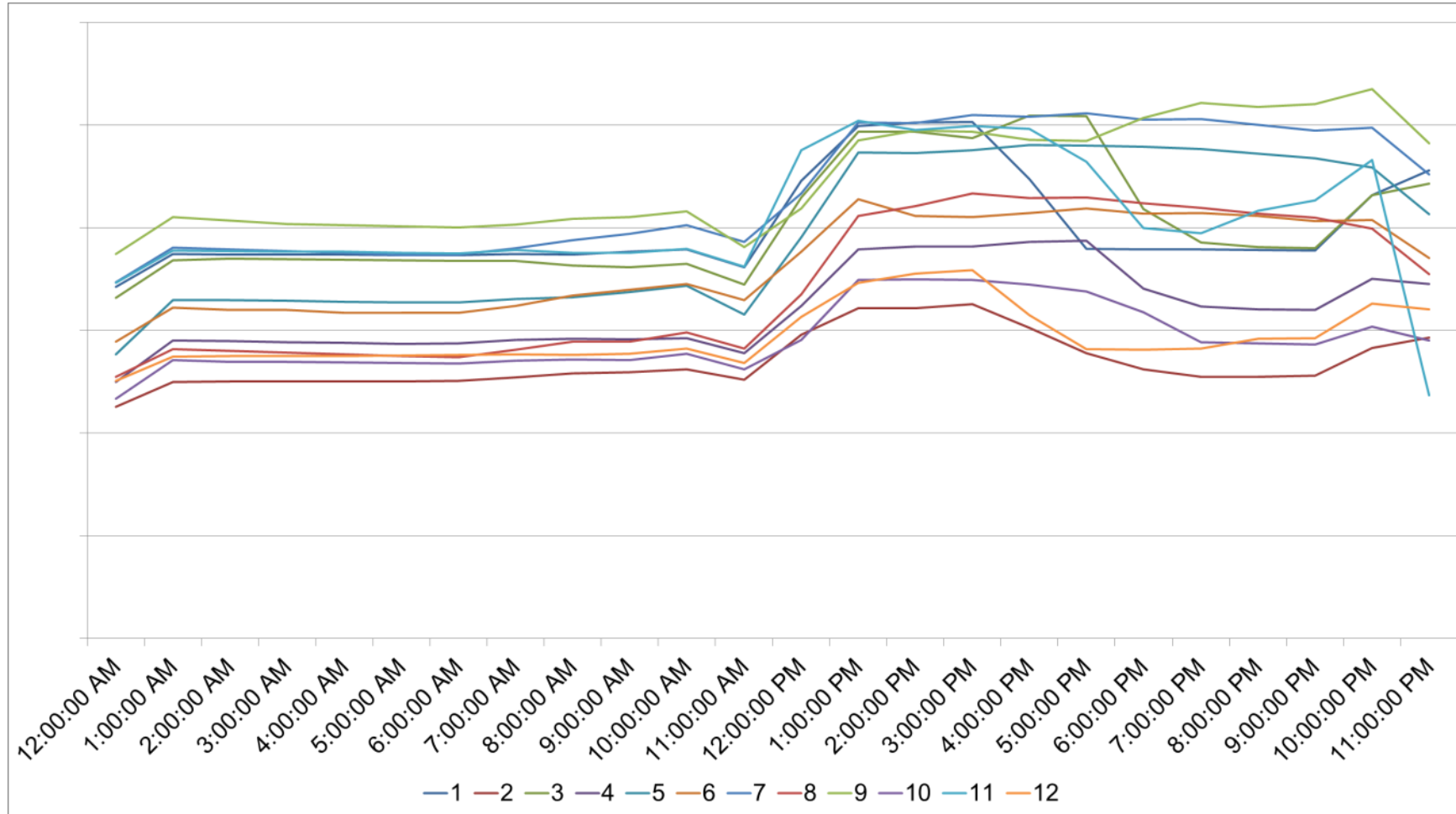

Indoor – Running Opposing Flower Rooms

Load shapes

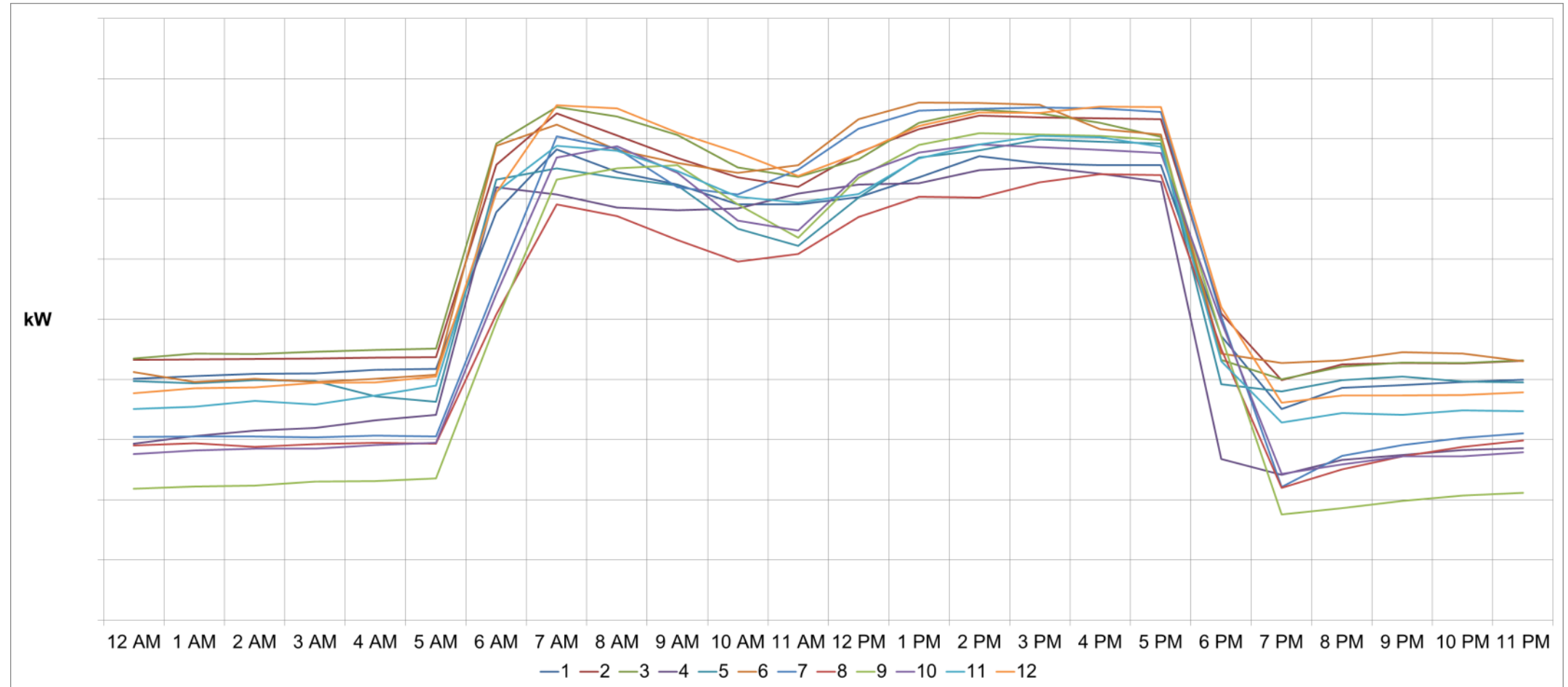

Indoor – Running Concurrent Flower Rooms

Load shapes

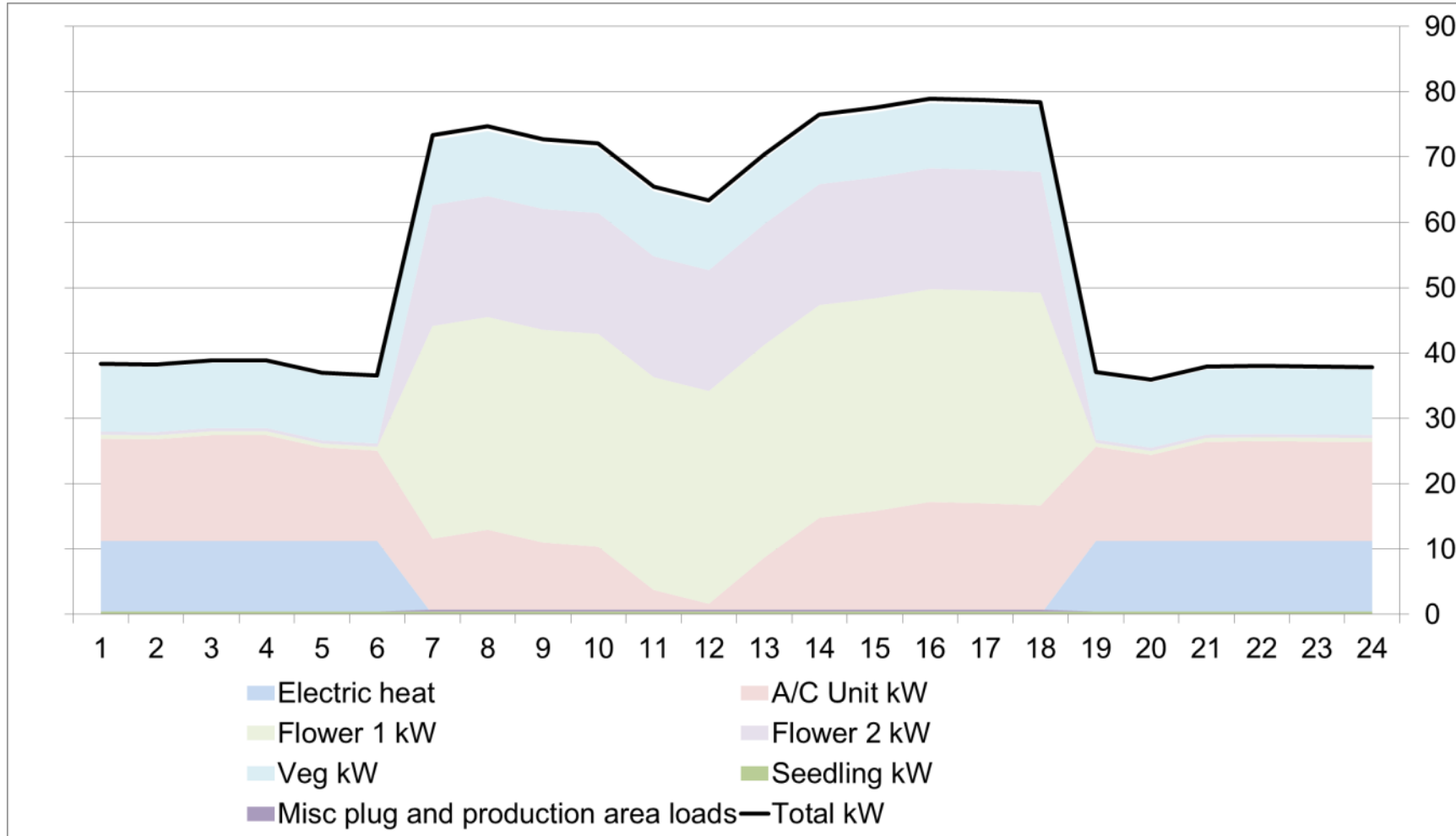

Indoor – Running Concurrent Flower Rooms

Weather Dependence

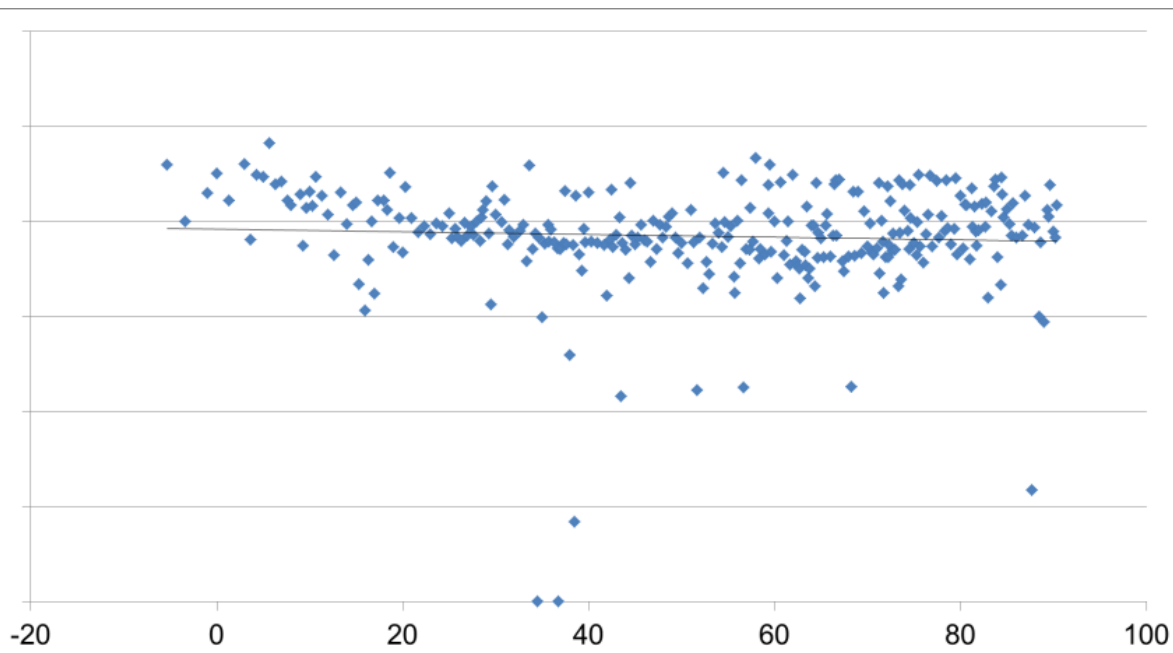

Lights On – dominated by process

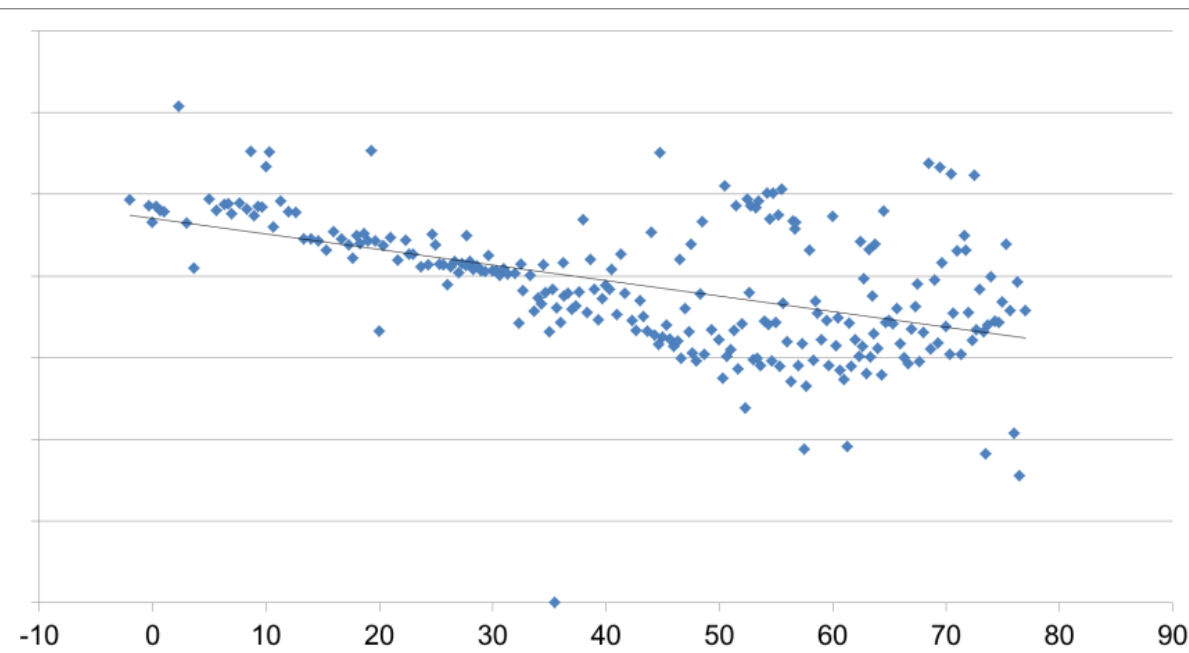

Lights Off – coldest temps may creep in



Horticultural Lighting

- Technologies
- Metrics
 - PAR
 - PPF
 - PPFD
 - PPE

Lighting Technologies



Horticultural Lighting Metrics

Visible light (400 nm to 700)

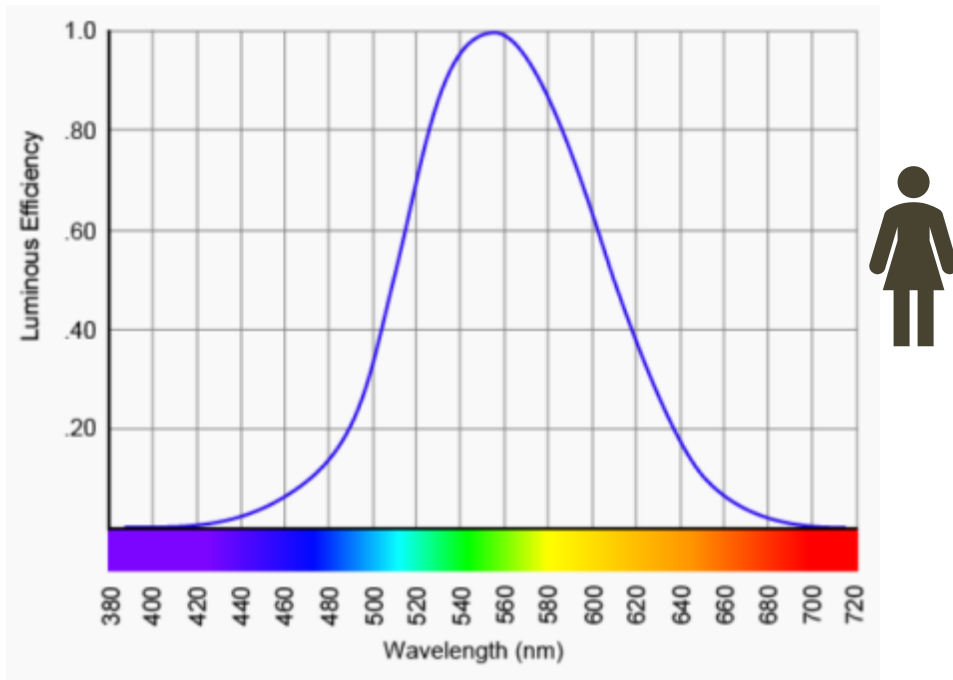

Visible light is weighted

PAR – Photosynthetic active radiation (400 nm to 700 nm)

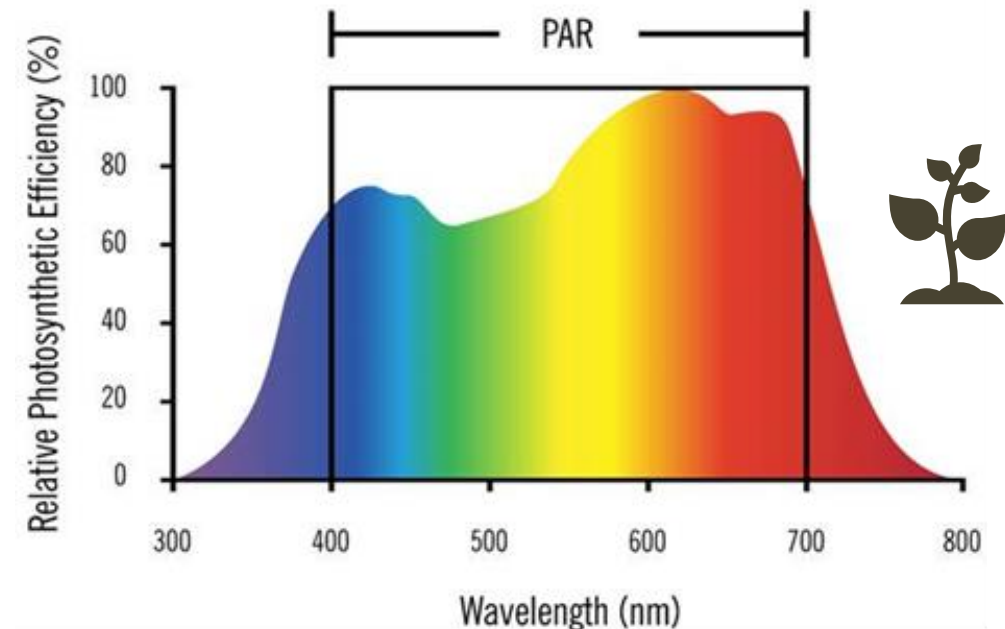

PAR is not typically weighted

Comparison of Spectrum Output: Daylight

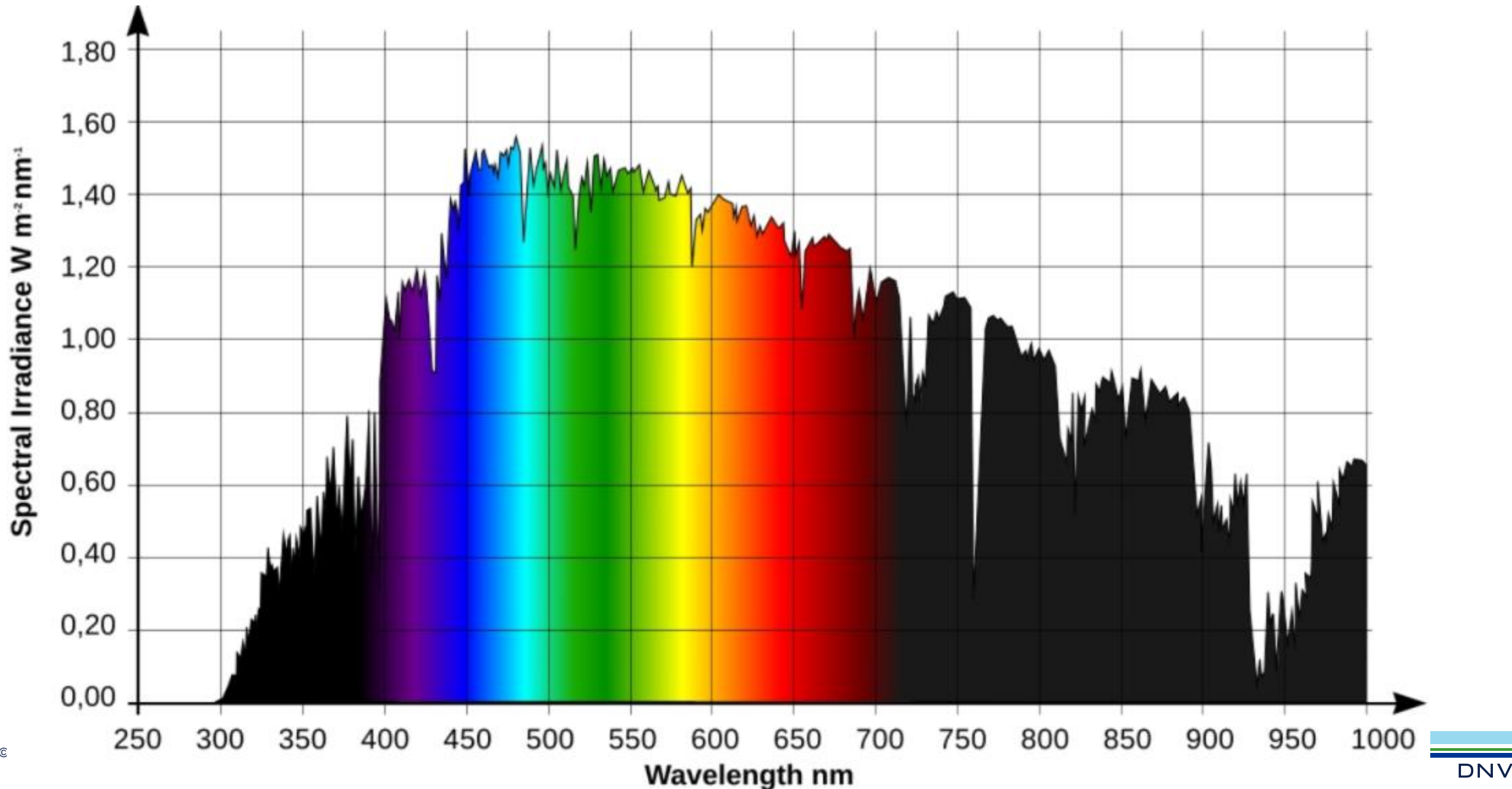

Comparison of Photometric Output

SPECTRAL POWER DISTRIBUTION CHART
PhysioSpec Indoor™



Measurements of Normalized
Photosynthetic Photon Flux

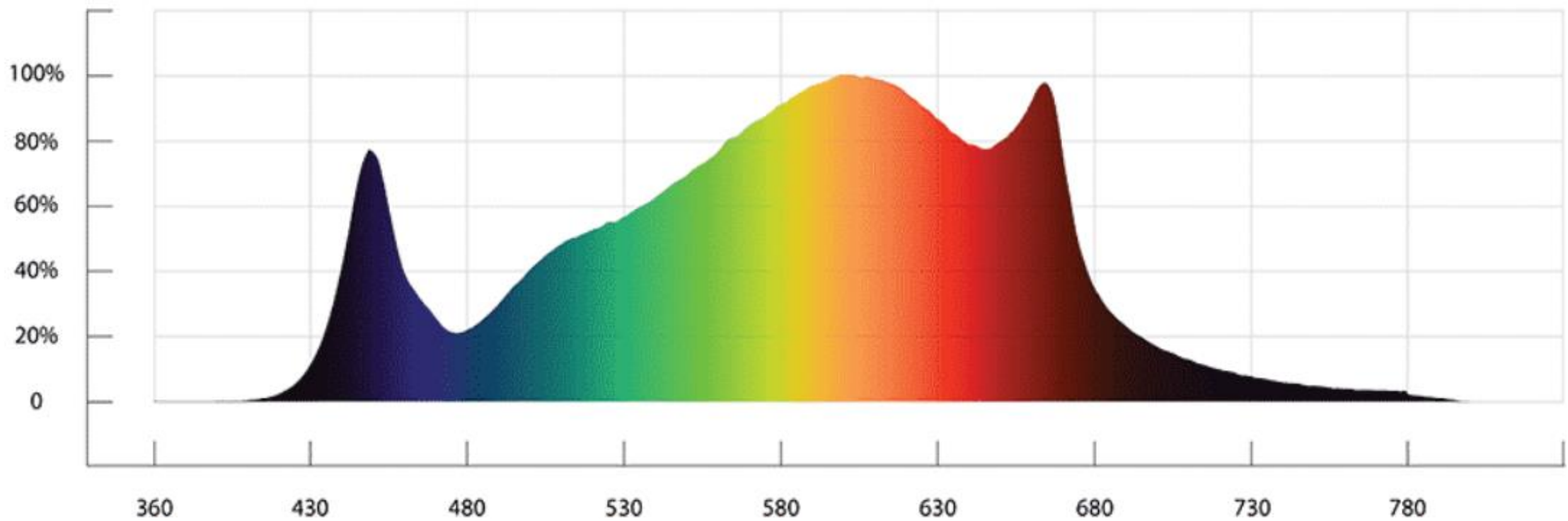

Horticultural Lighting Metrics



Property	Visible Light Spectrum	PAR Spectrum
Fixture Output (photons)	Lumens	PPF – Photosynthetic photon flux ($\mu\text{Mol/s}$) <i>Typical: 600-2000 $\mu\text{Mol/s}$</i>
Light Intensity (photons per area)	Footcandles or Lux	PPFD – Photosynthetic photon flux density ($\mu\text{Mol/s/m}^2$) <i>Typical: 300-1200 $\mu\text{Mol/s/m}^2$</i>
Efficacy (photons per input power)	Lumens/Watt	PPE – Photosynthetic photon flux efficacy ($\mu\text{Mol/J}$) <i>Typical: >2 for LED</i>

PPE: photons per input power

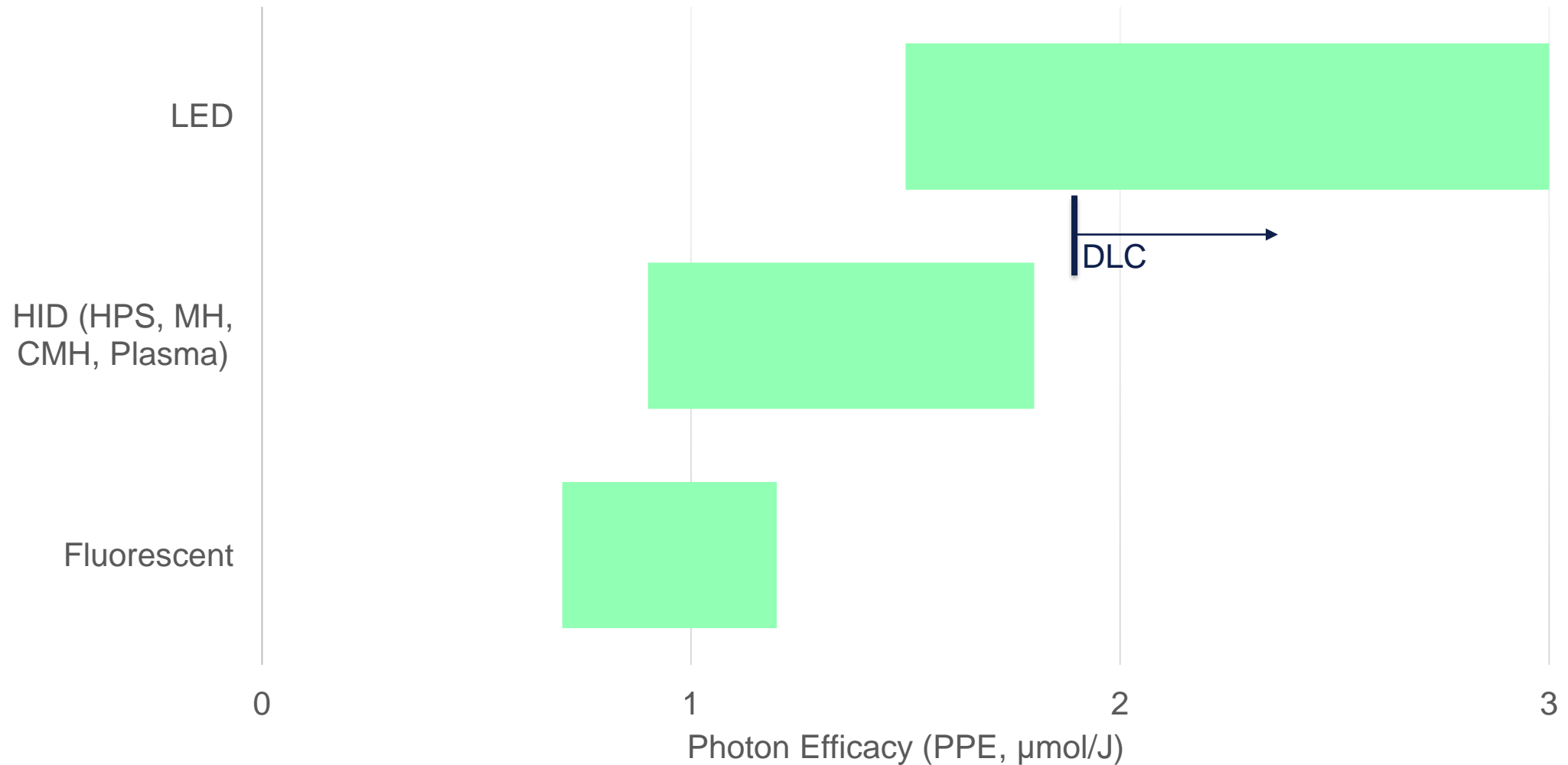

Efficiency Standards, and Certifications

DLC has created horticulture
qualified products list (QPL)

- $PPE \geq 1.9 \mu\text{Mol}/\text{J}$
- PPF output ($\mu\text{Mol}/\text{s}$) binned by spectrum range
- 5 year warranty
- SQD – spectrum distribution
- PPID – Light intensity distribution



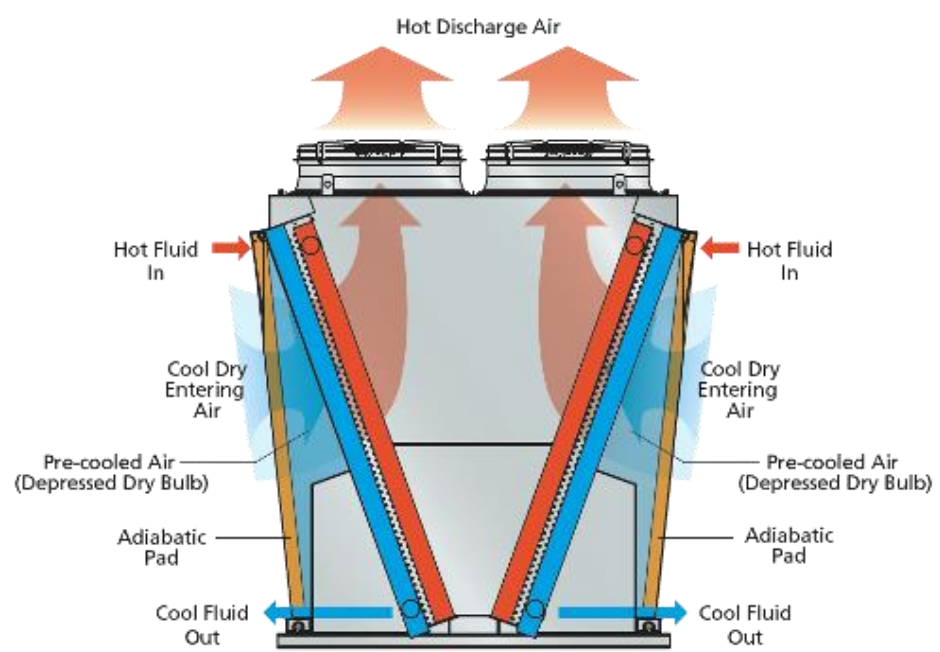

Dehumidification and Space Conditioning

Why dehumidification?

- Evapotranspiration
- Closed loop ventilation
- Little to no outdoor air
- “Vapor Pressure Deficit” drives nutrient uptake, growth



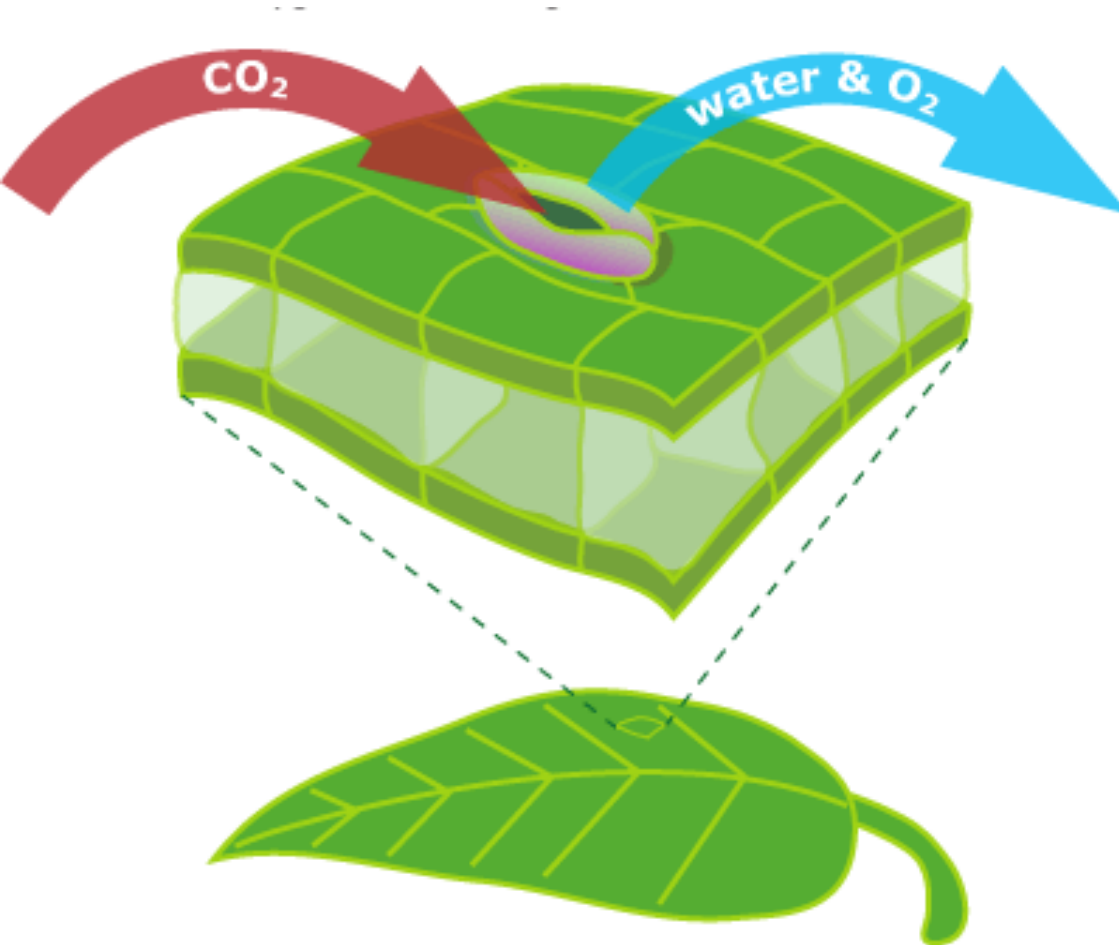

- Vast majority of irrigation water is released into air
- When the water within a plant transpires: phase change, liquid to vapor
- When there is a phase change there is latent heat at work (970btu/lb)
- Generic 1,900 sqft flower room may have ~8 tons evaporative sensible cooling from plants

- The evaporative cooling effect in closed grow rooms results in a low sensible heat ratio (SHR)
- $$SHR = \frac{\textit{Sensible heat load}}{\textit{Total heat load}}$$
- Flower room SHR (metered data) = 0.5 - 0.7
- Typical unitary equipment SHR = 0.75 - 0.80
- We've got a mismatch between load and equipment SHR

Irrigation Rates



Very important, relates directly to the latent loads of the space and the evaporative cooling effect



Manual and Automated watering both common



Inexperienced cultivators tend to estimate poorly



Varies week to week as plants grow. Need all the detail

How do we dehumidify

The removal of water vapor from the air

Typical Methods

**Mechanical
dehumidification
at the coils of an
AHU/FCU**

**Mechanical
dehumidification
through
dedicated
dehumidifiers**

**Desiccant
dehumidification**

- Incorporated into AHUs
- Dedicated units

Heat/Reheat

Lights On

Reheat required
only if lights do
not radiate
sufficient heat

Lights Off

Heating required to
offset evaporative
cooling of plants

SENSIBLE-HEAT RATIO IMBALANCE



In order to dehumidify at the cooling coils alone, we will need to apply more sensible than is required (more energy) in order to provide the latent that is required.



If we apply more sensible than is required, we will have to compensate with additional reheat (more energy use).

Overcool AND overheat, just to address moisture

Many Different Options

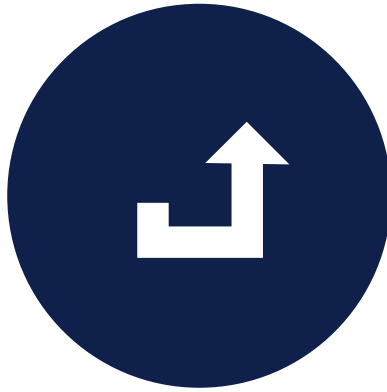

Direct Expansion

Cool air directly

Rooftop units

Split systems

VRF, ASHP, ...



Chillers

Chilled water supplied to AHUs

Air cooled

Water cooled

Gas-Fired

Heat recovery

Table of Archetypal Designs

Cooling	Heating	Dehumidifying
Packaged RTU	Packaged Furnace	Supplemental DH likely
Minisplit Heat Pumps	Minisplit Heat Pumps	Supplemental DH likely
VRF	VRF	Supplemental DH likely
Water-source HP Loop + Tower	Water-source HP Loop + Boiler	Supplemental DH likely
Air-cooled Chiller	Boiler	Supplemental DH unlikely
Water-cooled Chiller	Boiler	Supplemental DH unlikely
Gas-driven Chiller	Boiler	Supplemental DH unlikely

- All: Air destratification wall fans – eliminates microclimates that breed pathogens, strengthens plant stalks
- Supplementary Standalone DH – commonly rejects heat into room, newest models reject heat outside

EE opportunities

- LED lighting
- Cooling opportunities
- Various dehumidification systems
- Heat recovery chillers
- Combined heat and power



Will LEDs become standard practice?

Some growers we have direct and indirect experience with are not willing to “risk” a retrofit to LED, though the winds are shifting

- Early LEDs *were* worse, combined with snake-oil sales tactics gave adoption a stuttering start
- State regulations can drive LED adoption – MA, IL, elsewhere
- Power supply infrastructure limitations can tip scales

Hort Lighting Costs

1000w HID
600w LED
most common

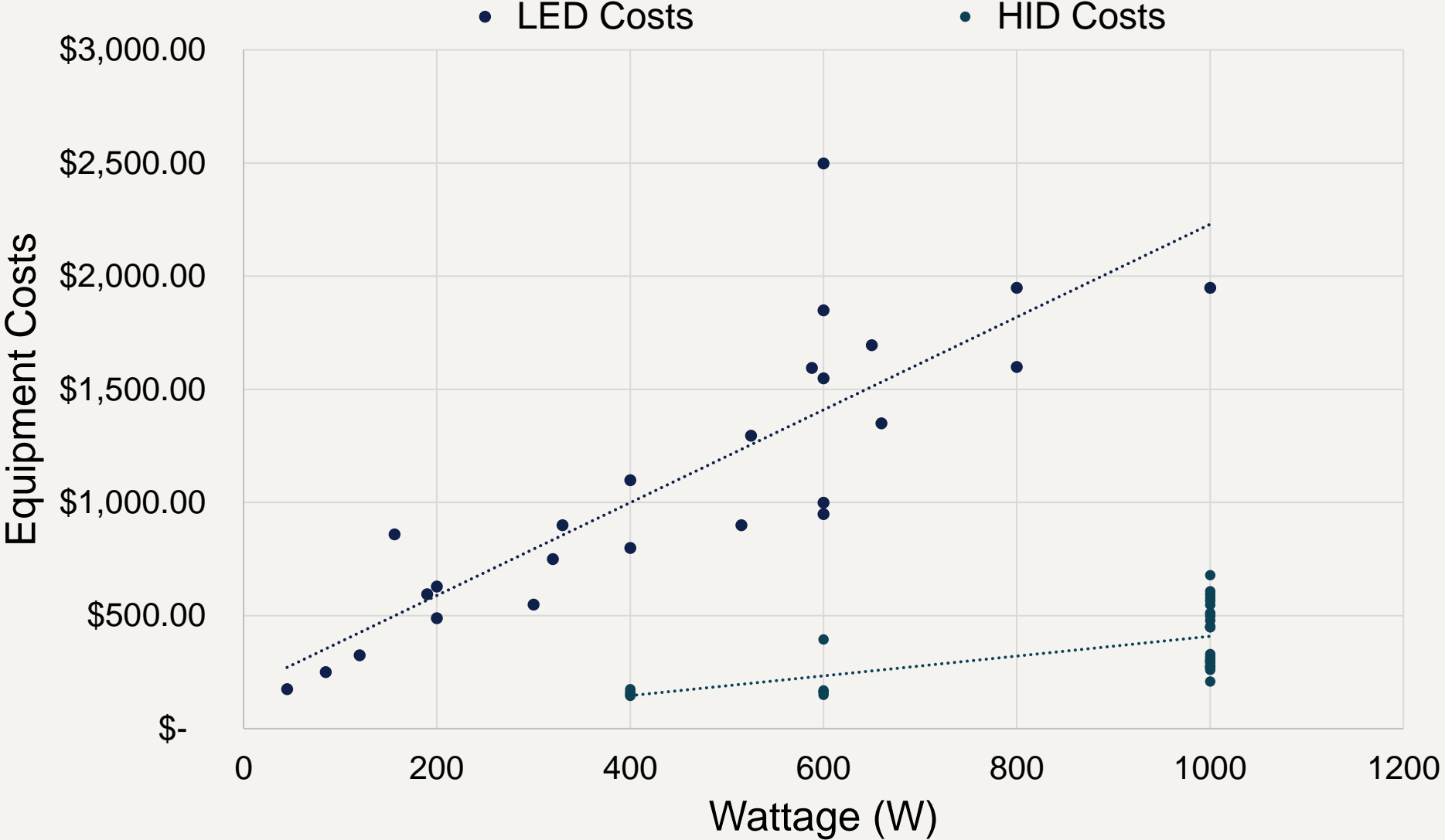

2019 data, expect 5-10% cost reductions in LED

HVAC Opportunities

Smarter Dehumidification

EER of Cooling Equipment

Heat Recovery

**Adiabatic (evaporative) Condenser Cooling
and Water-side Economizing**

Indirect Economizing

Waterside economizing or dry-cooler

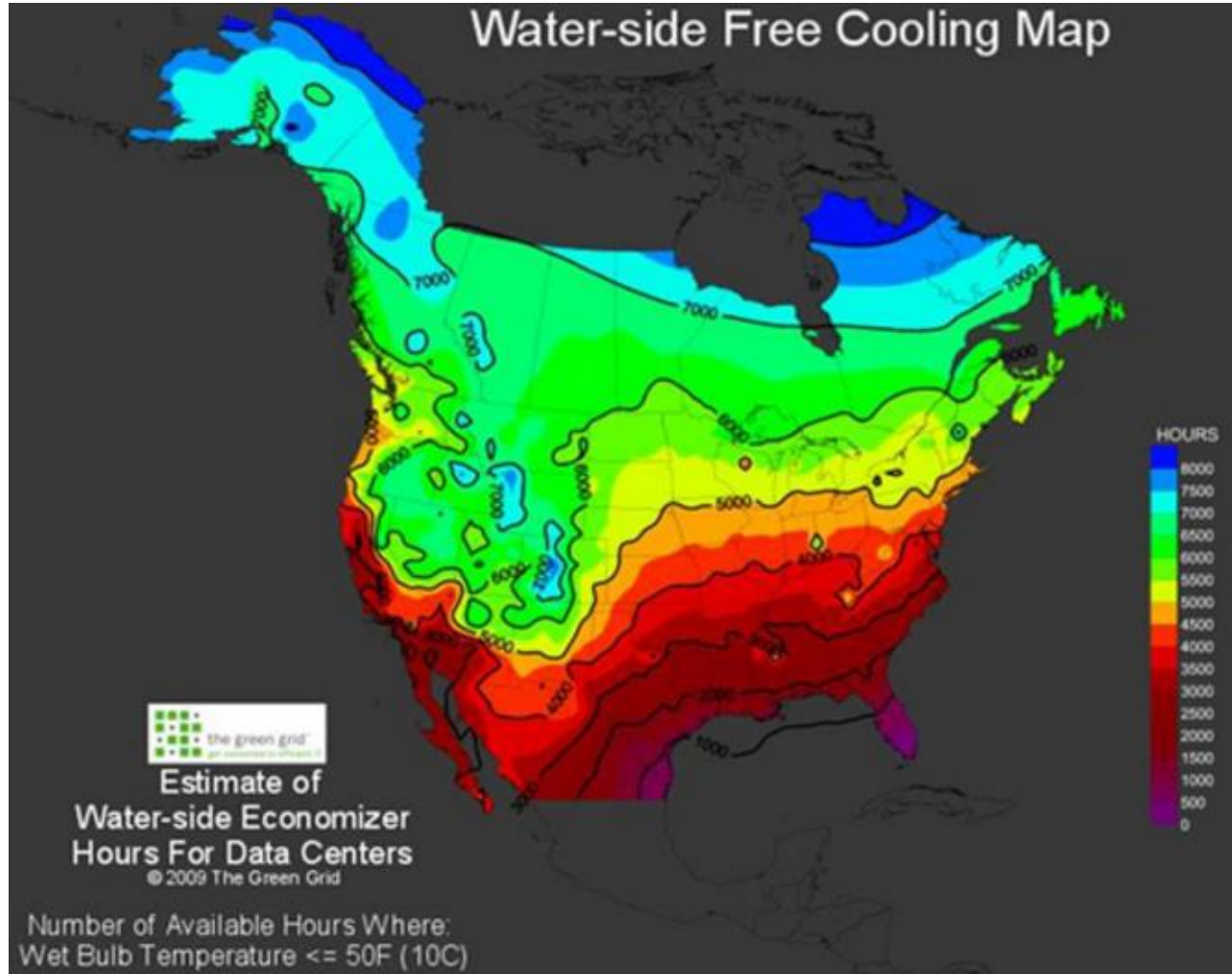

- Uses evaporative cooling capacity of a water tower to offset chiller energy use when conditions permit
- Provides some cooling capacity redundancy
- Typically a cost effective retrofit

Various dehumidification systems

Each of these options provides the *potential* for energy savings over traditional coil-based mechanical dehumidification.

**Wrap-around
HX**

**Low SHR
optimized**

**Desiccant
Wheel**

The design needs to reflect the operation to ensure the system matches the needs.

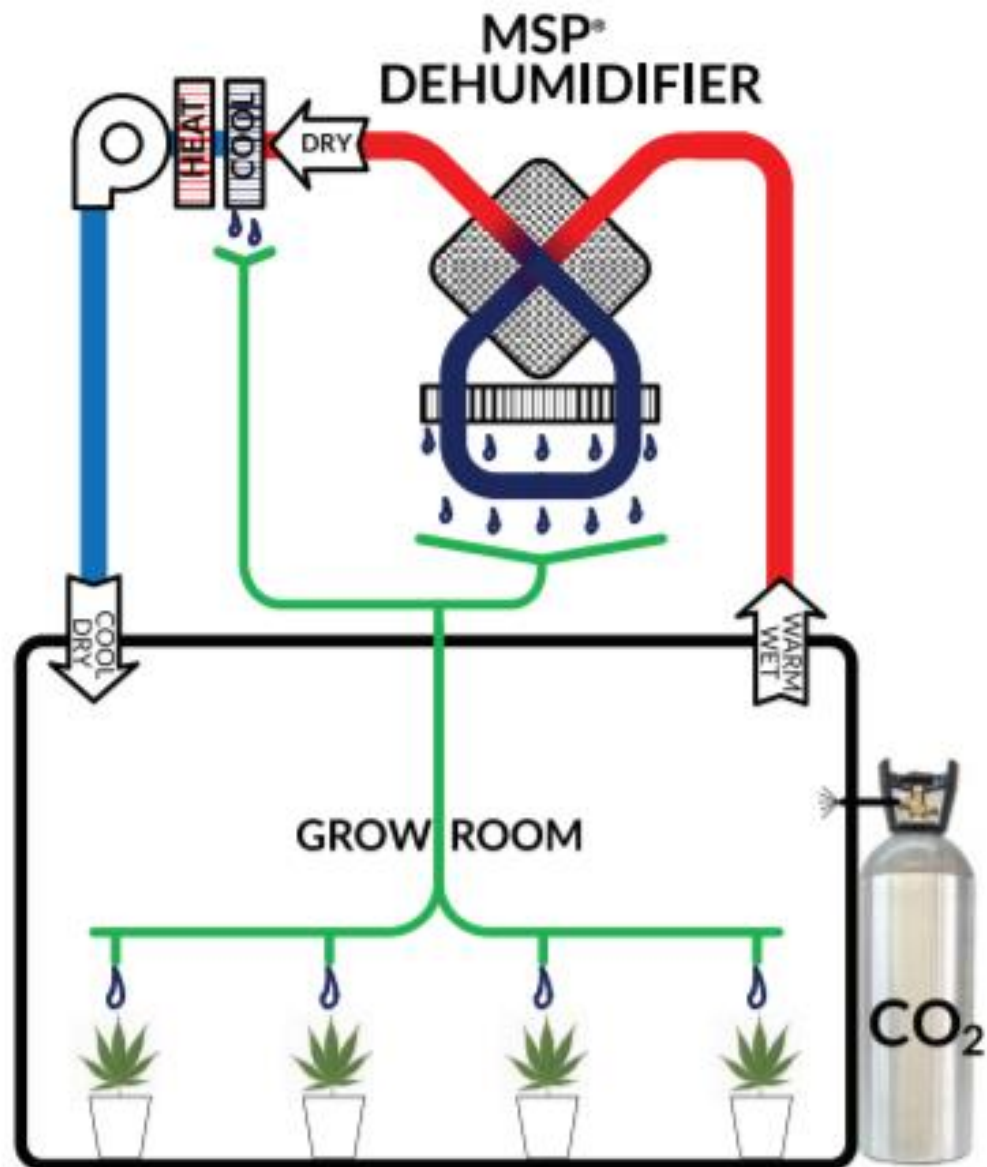

Wrap-around dehumidification

MSP, Adaptiiv and others

Low SHR Optimized

Dehumidification Schematic

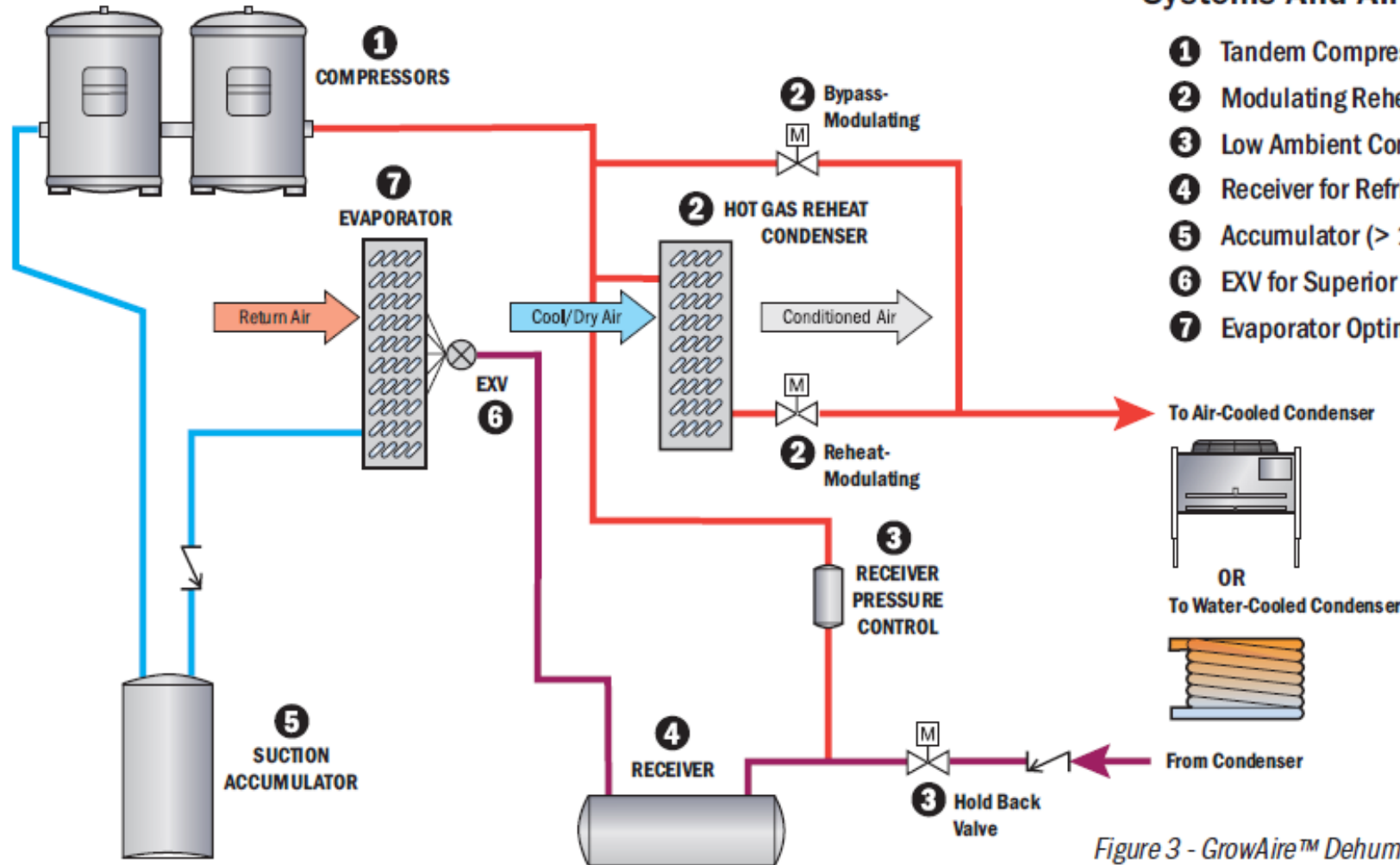

Major Differences Between GrowAire™ Systems And Air Conditioners

- 1 Tandem Compressors
- 2 Modulating Reheat Valves and Hot Gas Reheat Coil
- 3 Low Ambient Control (Receiver Pressure and Hold Back Valves)
- 4 Receiver for Refrigerant
- 5 Accumulator (> 15 Ton)
- 6 EXV for Superior Evaporator Control
- 7 Evaporator Optimized for Humidity Removal

Figure 3 - GrowAire™ Dehumidification Schematic

Desiccant Dehumidification

A desiccant is a substance that attracts water vapor from air through adsorption or absorption

Adsorption

No phase change

Silica gel

Absorption

**Desiccant changes
physically or
chemically**

Typically liquid
Lithium chloride

Desiccant Dehumidification

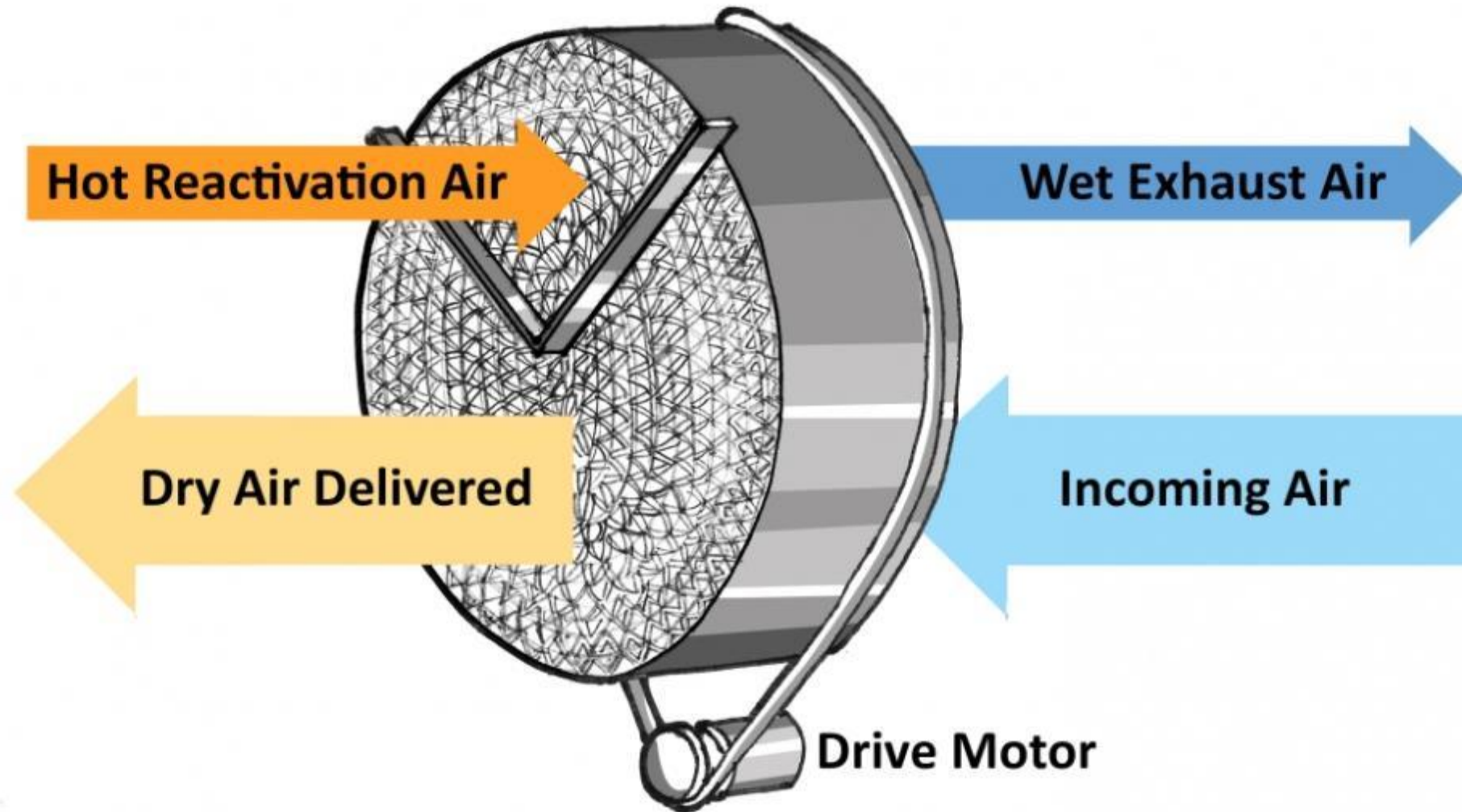



Heat recovery chiller

- Heat is needed as part of the mechanical dehumidification (reheat) process
- Heat recovery chiller can produce simultaneous chilled water and waste heat for reuse

Heat Recovery Chillers

Recover heat rejection from the condenser loop via water to water heat exchanger

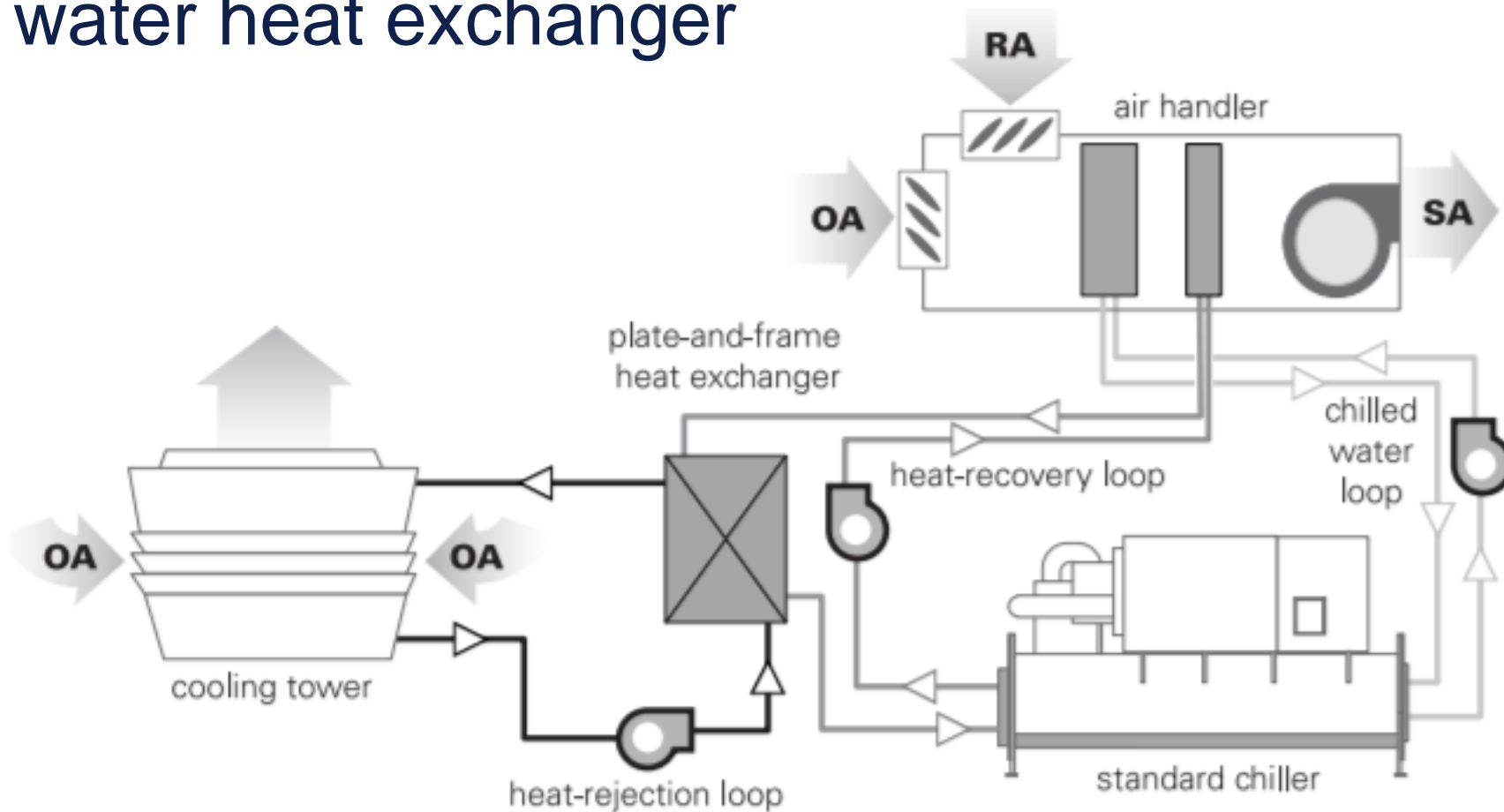

Highest efficiency
and cost

Must have
simultaneous
cooling and
heating loads
(dehumidification)

Engine driven chiller with heat recovery

- Fossil fuel fired engine turns the chiller compressor (water cooled)
- Heat recovered of the engine jacket and exhaust used for re-heat and facility/DHW needs
- Right sized units provide a good opportunity for base loading units and high thermal efficiency

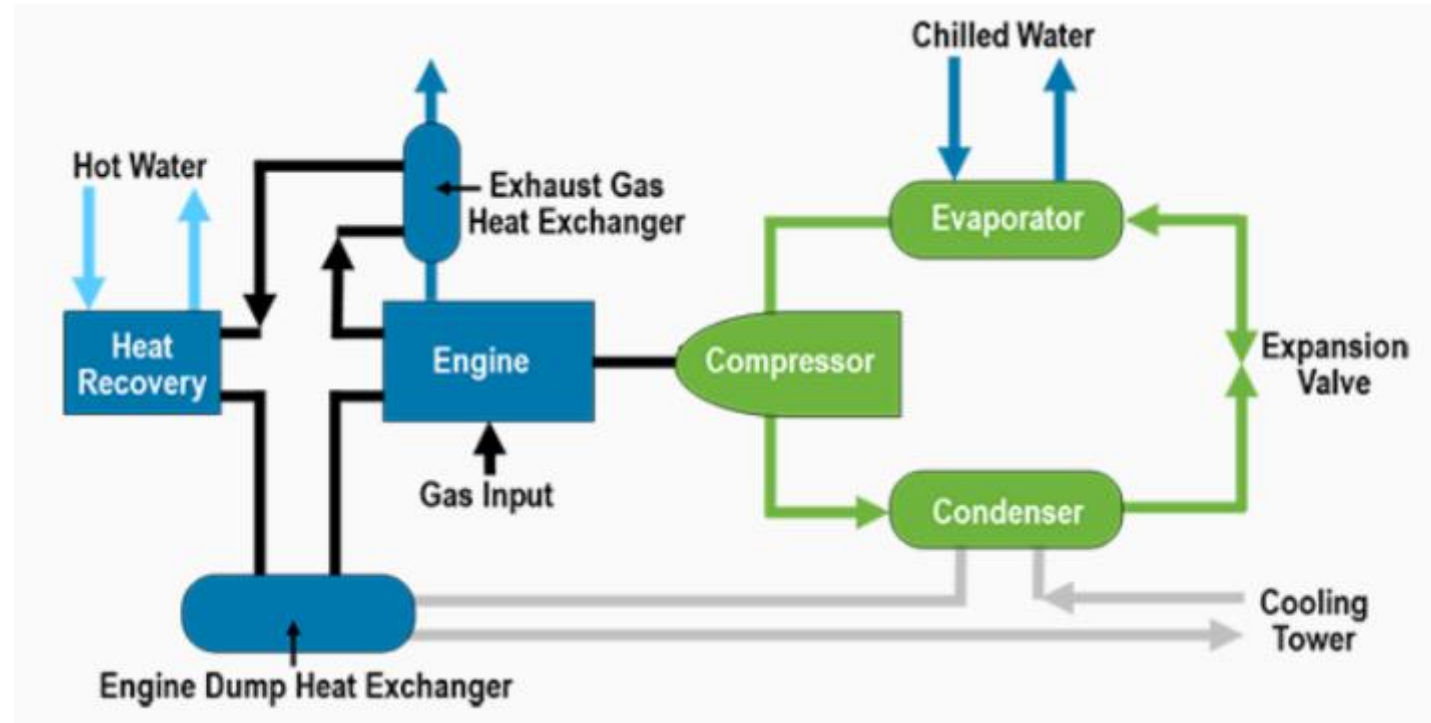

www.tecochill.com

Combined heat and power

- Dependent on facility HVAC design
- Must have a regular need for the waste heat off the CHP to ensure high thermal efficiency
- Staggered flower rooms provide relatively flat electric and thermal load profile
- Emissions from the engine can be used to introduce supplemental CO₂ to the grow rooms
- Several vendors targeting this market
- History in greenhouses

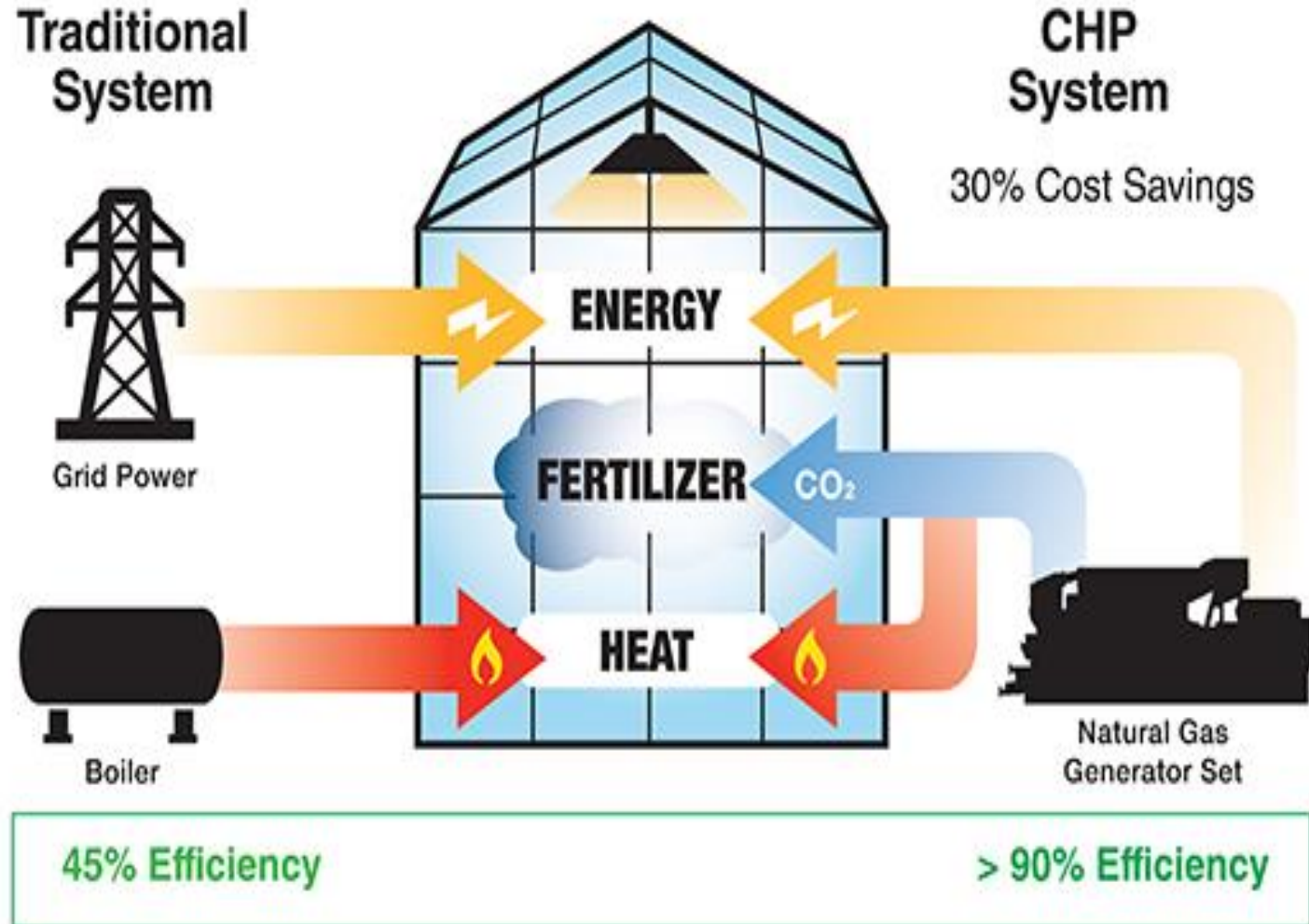

Implementing retrofit vs new construction measures

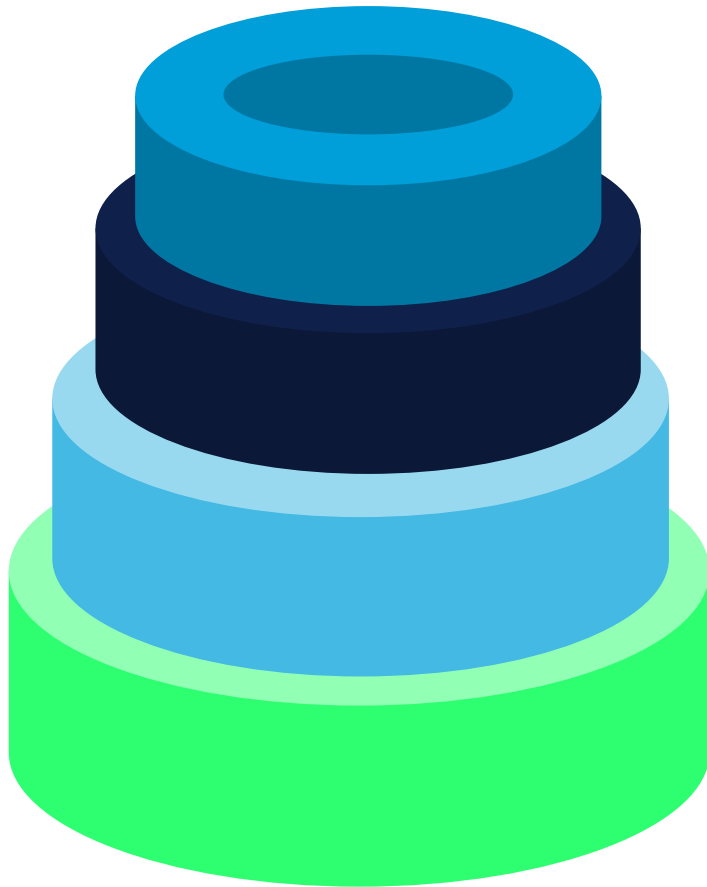

Retrofit Challenges

Typically considering the full project cost, and not the incremental cost between standard and high efficiency options

- The savings need to support a greater cost

Potential impact on the operation of the facility

- Will critical systems be affected during the work?

Retrofit advantages

Potential access to historical facility operating data

Utility EE Programs Today



They want your projects!

Custom C&I programs in all nearby states are engaging with indoor cultivation

Technical assistance, design charette/review, and calculation support is common

Baselines: still point of discussion, but some ISP exists and norms are forming



CONTACT US



Dan Birleanu

Dan.Birleanu@dnv.com

978-457-5311



Ryan Pollin

Ryan.Pollin@dnv.com

978-521-2550 x212